

OVER
50
YEARS
of success

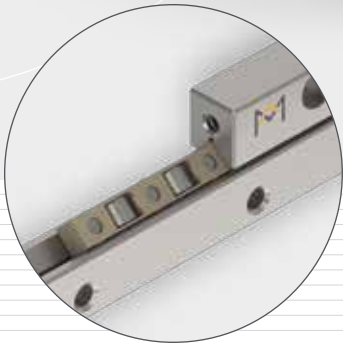

LINEAR SLIDES TYPE RTN/RTL

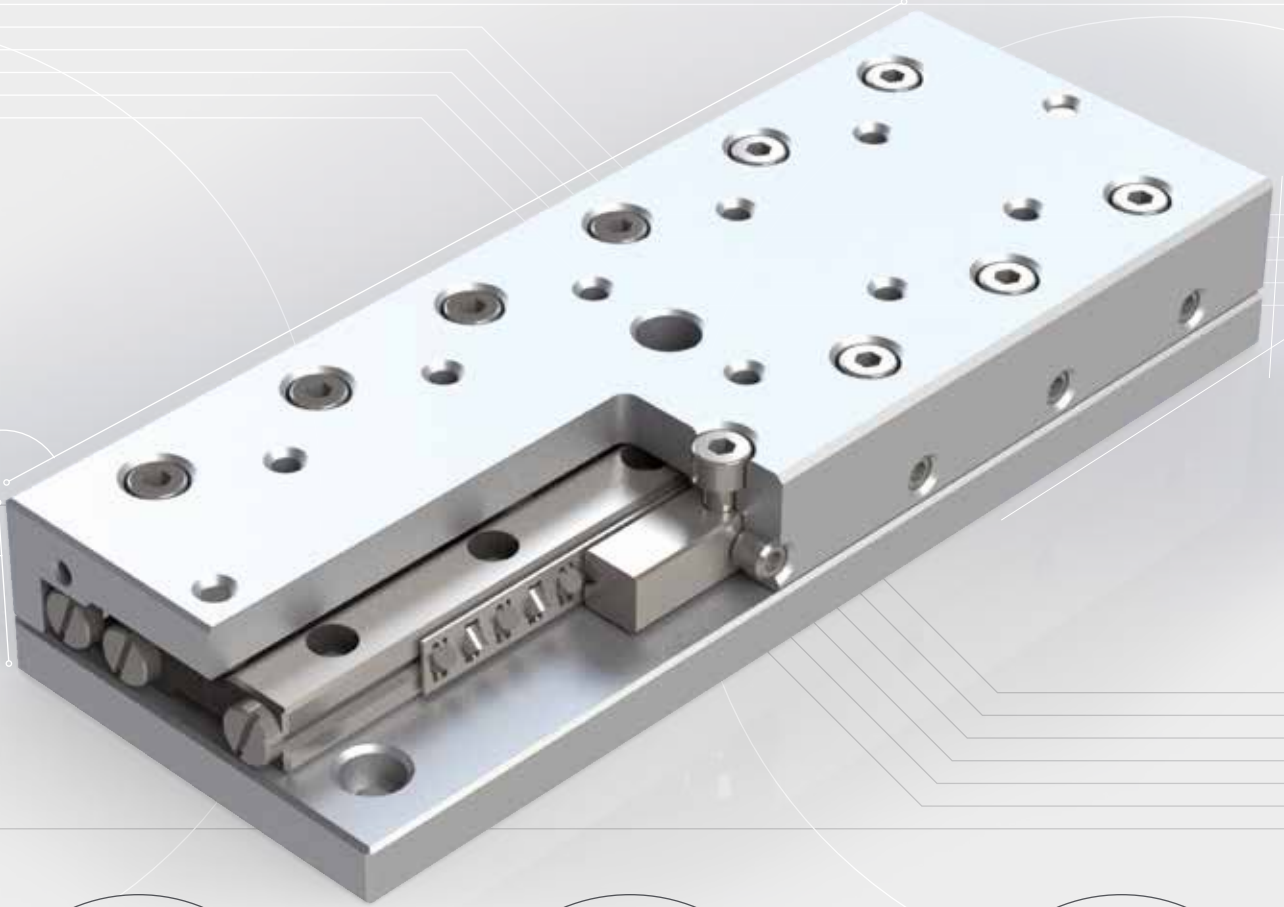

Company's headquarters in Dedemsvaart, Netherlands



Innovative design and manufacture of precision linear bearings, frictionless slides, positioning stages and engineered-to-spec motion systems.





INTRODUCTION

PM has engineered and manufactured innovative and top quality precision linear bearings and slides at our research and production facilities in the Netherlands since 1966. We are experts in finding solutions that meet the specific requirements of a wide variety of industry applications. A trusted partner for hundreds of industry heavyweights around the globe, our client base ranges from the semiconductor industry, medical technology and metrology sectors, to industrial automation, space and defence industries.

COMPANY

The key to the exceptional quality of PM products lies in our highly specialised manufacturing machinery and facilities. Specifically, the PM production facility is temperature controlled and built to suppress and minimise distortions caused by vibration. Our precision rails are produced with remodeled, non-standard machinery. The resulting high quality of our products makes PM an attractive supplier for various high-tech industries including semiconductor, optical and life sciences.

NEW PRODUCTS

We constantly deploy the latest technologies to create new products or functionally enhance existing products in our range. Clients typically choose to work with PM for our proven ability to meet a complex set of requirements, mostly including maximum performance of parts in the most compact of spaces. We are always working to further refine the performance of PM products, in order to ensure that we consistently meet the requirements of clients in high-tech industries. The following new PM products are the result of our relentless drive to be operating at the cutting edge of the latest technologies:

- **Linear bearing type RNG:** is a compact design with high load capacity. Available with optional Anti Cage Creep solution (ACC). Perfectly integrates robustness and compactness.
- **Micro roller slide type PMMR:** featuring crossed-rollers. Designed for best performance in micro-sized applications.
- **Flat Mounted Bearing type FMB:** is an extremely flat, low-friction and easy to install table bearing.

CUSTOMISED PARTS

In addition to offering high-quality standardised products, we design and manufacture engineered linear bearings and positioning systems meeting our clients' application-specific requirements.

PM combines the latest knowledge from its in-house R&D department, developments in manufacturing technology

more widely as well as performance insights generated by industry deployment of precision applications.

Over the past 50 years PM has expanded its reach to serve a global client base. Our experienced, multilingual engineering and sales teams stand ready to work with you in realising your demanding projects.

Technical data in this catalogue is based on standard quality grade Q8 (no suffix). For higher quality grades please contact our product experts to discuss your requirements.

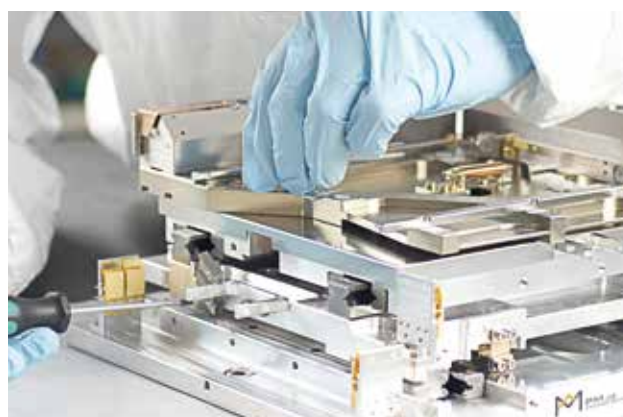

DISCLAIMER

This catalogue is the result of a full revision of its previous edition. It reflects the latest progress in linear bearings technology as well as insights gathered from industry application. Any information from previous editions that does not correspond to the data in this current edition, is therefore invalid. Due to the continuous development of our product range, we reserve the right to make modifications without prior notice.

© Copyright October 2020, second edition
PM B.V. - Discover Precision

Reproduction in part or in whole is only allowed with written authorization of PM.



PRODUCT OVERVIEW

PM slides are ready-to-install single axis components with capacity for limited linear movement. These crossed roller slides use PM linear bearings type RSD come factory-preloaded, thus assuring consistently high running accuracies, extremely low uniform friction coefficients and long operating lifetimes. With a variety of models and a wide range of sizes available, the designer is given maximum flexibility to find an appropriate solution for all sorts of applications requiring linear movement.

Each type comes with attachment holes drilled to standard configuration to facilitate quick and easy assembly into your application. Thanks to their excellent running characteristics together with their proven solid reliability, these slides are today's standard for applications in the general machine industry's factory automation, including in high precision equipment. Custom designs can be supplied according to your specifications.



1. CROSSED ROLLER SLIDES TYPE RT

- Stroke lengths of 10 to 950 mm
- For highest accuracy performance
- Normal to high load capacity
- Steel and cast-iron slide bodies
- Available in 6 standard sizes



2. CROSSED ROLLER SLIDES TYPE RTA

- Stroke lengths of 10 to 950 mm
- Extremely low uniform friction coefficient
- Normal to high load capacity
- Aluminium slide bodies
- Available in 6 standard sizes



3. DUST-PROTECTED SLIDES TYPE RTNG

- Stroke lengths of 10 to 250 mm
- Protection against dust and dirt
- For highest accuracy performances
- Steel and cast-iron slide bodies
- High rigidity



4. LOW PROFILE SLIDE TYPE RTS

- Stroke lengths of 12 to 130 mm
- For highest accuracy performance
- Low overall height with high stiffness
- Steel slide bodies
- Available in 3 standard sizes

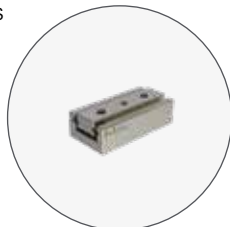

5. MINIATURE BALL SLIDES TYPE PMM

- Stroke lengths of 5 to 70 mm
- Ultra-compact and lightweight design
- For rapid and precise movements
- Slide parts made of stainless steel
- Available in standard 3 sizes



6. MINIATURE CROSSED ROLLER SLIDES TYPE PMMR

- Stroke lengths of 5 to 70 mm
- All parts made of stainless steel
- For highest stiffness and accuracy requirements in the smallest of application spaces
- $V_{max}=2 \text{ m/s}$, $a_{max}=200 \text{ m/s}^2 (20g)$
- C_{dyn} up to 1020 N



TECHNICAL DATA

ASSEMBLY

For each type the mounting holes are drilled to standard configuration in the slide top and slide base facilitating quick and easy installation into the application. Threaded holes in the slide parts are according to ISO-standards. Please note that dimensions listed in this catalogue are in mm.

PM linear slides are precision devices; proper mounting is a prerequisite for their performance according to specifications. Slides must be mounted onto rigid, fine-machined (preferably fine-milled or grinded), flat surfaces and must be supported over their entire base length. Specifications as listed are only valid when these conditions are met.

The surface of the side opposite to the preload set screws is ground parallel to the slide axis and can therefore be used as a reference face for mounting the slide into the application.

OPERATING TEMPERATURE

PM slides are capable of operating in a temperature range of $-30\text{ }^{\circ}\text{C}$ to $+120\text{ }^{\circ}\text{C}$. For slides which contain plastic components (plastic cages), the operating temperature range is $-30\text{ }^{\circ}\text{C}$ to $+80\text{ }^{\circ}\text{C}$.

MAXIMUM VELOCITY AND ACCELERATION RTN / RTL, RTNG and RTS types crossed roller slides

Max. recommended speed $v = 50\text{ m/min}$.

Max. acceleration $a = 8\text{ m/sec}^2$.

PMM type ball miniature slides

Max. recommended speed $v = 50\text{ m/min}$.

Max. acceleration $a = 8\text{ m/sec}^2$.

PMMR type crossed roller miniature slides

Max. recommended speed $v = 120\text{ m/min}$.

Max. acceleration $a = 200\text{ m/sec}^2$ (20g).

INTERNAL STROKE LIMIT SCREWS

Crossed-roller slides RTN/RTL and RTNA/RTLA have internal stroke limit screws in the center line of the slides. These screws are for emergency use only and may not be used as a regular stroke end stop, as this can cause permanent damage to the linear bearings.

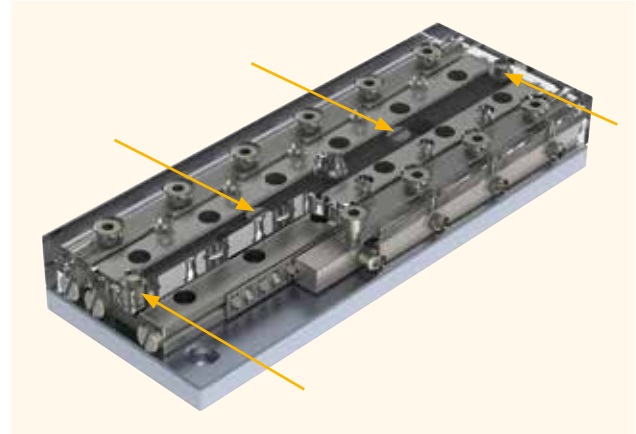

Example of location internal stroke limit screws

DELIVERED CONDITION

PM slides are ready-to-use. The slides are factory preloaded by the use of lateral set screws and free of play. The amount of preload is approximately 10% of the dynamic load capacity. The slides are delivered with a small quantity of oil for lubrication which also protects the rails in the slides against corrosion. The quality grade of the crossed roller linear bearings which are used in the linear slides is in standard accuracy grade Q8.

The slides are free from stick-slip. The coefficient of friction range for slides fitted with balls or cylindrical rollers is 0.0005 to 0.003. PM slides are manufactured according to the best manufacturing standards, offering high smoothness and precision of movement.

PMM and PMMR type of miniature slides are factory preloaded by means of geometry pairing.

SERVICE

PM slides are factory-preloaded and don't need readjustment. Depending on the application requirements the linear bearings need re-lubrication. There are no specific calculations to determine the lubrication intervals for linear bearings, thus it must be determined for each application. However, we recommend a small quantity of lubrication at least twice a year for oil and at least once a year for grease.

The lubrication can be applied to the linear bearings using the lateral gap between the rails. If this is not possible cause of the design of the machine we advise the use of special lubrication holes which can be added to the rails. If this is the case for you, please consult a PM advisor.



STORAGE

PM slides are precision components and need to be handled with great care. Slides are delivered in a package, special developed for optimum protection against external vibrations and contamination. For transport and storage use the original package. Slides should be stored at constant room temperature and under clean and dry conditions. Remove the slides from their packaging just before use.

LOADS AND MOMENTS

Slides listed in this catalogue are able to carry loads and moments in any direction. Load ratings are compliant with ISO and DIN standards for calculating roller bearings (ISO standard 281, for miniature slide type PMM DIN 636, part 3). To ensure high running accuracy and to prevent the occurrence of play, any vibration and overloading must be avoided.

Load capacity C , defined in ISO76-1987, is the maximum downward load or force located in the center of the upper part in horizontal zero-position.

M_I = Pitch moment: when a load is cantilevered (not symmetrically mounted) off the end of a slide, parallel to the direction of travel.

M_d = Roll moment: when a load is cantilevered off the side of a slide, perpendicular to the direction of travel.

M_r = Yaw moment: when a force causes a rotation moment around the centre of an axis.

Exceeding of the listed moment ratings may reduce the lifetime of the bearings and can degrade accuracy. Please feel free to contact one of our product specialists for information.

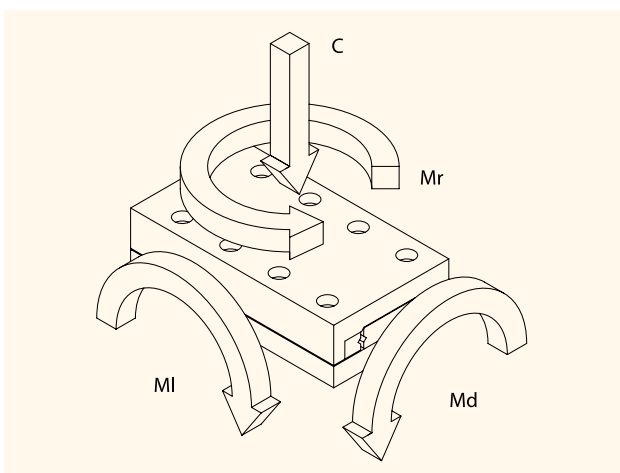

VACUUM AND CLEANROOM COMPATIBLE

The majority of PM slides can be prepared for use in (ultra-high) vacuum or cleanroom environments. Special care has to be taken, for example when selecting low outgassing materials, special lubricants, surface finishings, vented stainless steel fasteners for use in blind tapped holes, special ball- or crossed roller cages as well as switches and wires. Slides are assembled in our modern cleanroom cells certified to ISO/FDIS 14644-1 class 6 with cleanspots class 5.



CUSTOMISED LINEAR SLIDES

In a situation that a standard product does not suit your application we offer customised product service. For example in:

- Special geometry
- Non-standard materials
- Customized cages
- Vacuum and UHV-compatibility
- Low till non-magnetic linear bearings
- Improved raceway surfaces
- Higher load ratings
- Higher speeds / accelerations

With over 50 years' experience we are well equipped and capable to fulfil your orders meeting even the most demanding requirements

Please consult your PM advisor for more information.



Customised miniature slide PMM 2



Type RTN and RTL frictionless precision slides are preloaded linear motion units, ready for mounting. The proven design of this model offers a wide range of benefits including high rigidity, no stick-slip and unprecedented precision in linear movement due to the double-sided rail on the slide base which eliminates machining errors.

SLIDE BODY MATERIALS

1, 2, 3 and 4 mm series are made of black oxide finished steel, while 6 and 9 mm series are available in cast-iron

FEATURES AND SPECIFICATIONS

- Incorporates preloaded linear bearings type RSD and double-sided rail, including roller cages.
- Slide top and slide base have equal lengths
- 2 standard stroke lengths (N and L stroke).
Linear strokes are limited by internal mounted hard end-stops, two in the slide top and one or two in the base-plate, depending on RTL or RTN version.
RTN: for normal stroke/travel, with normal loads
RTL: for longer stroke/travel, with reduced loads
- Suitable for use in horizontal and vertical application
- All mounting surfaces are precision ground. One flank of the slide (i.e. the side opposite to the adjustment screws) is ground parallel to the linear bearings to serve as a reference face
- The slide top is provided with tapped attachment holes, drilled to standard configuration. The slide base comes equipped with countersunk through holes, which accept socket head screws. Pre-drilled holes enable simple mounting
- The ends of the upper slide comes with tapped holes that permit easy attachment of covers, bellows, or other shields to prevent that contaminants enters the slide and keep the linear bearings clean
- For running accuracies please refer to page 142

OPTIONAL FEATURES

- Selected slides can be supplied with a height tolerance of ± 0.01 mm
- Cages can be replaced by plastic crossed roller type KZR or type KCLK equipped with balls
- Higher accuracy grade slides
- Stainless steel slide parts
- SF finishing for linear bearings offering smooth and ultra-precise operation
- UHV compatible version

ORDER NOTES

Please specify the following in your note:

- Model no. and quantity needed

Example: 1 piece slide type RTN-3100

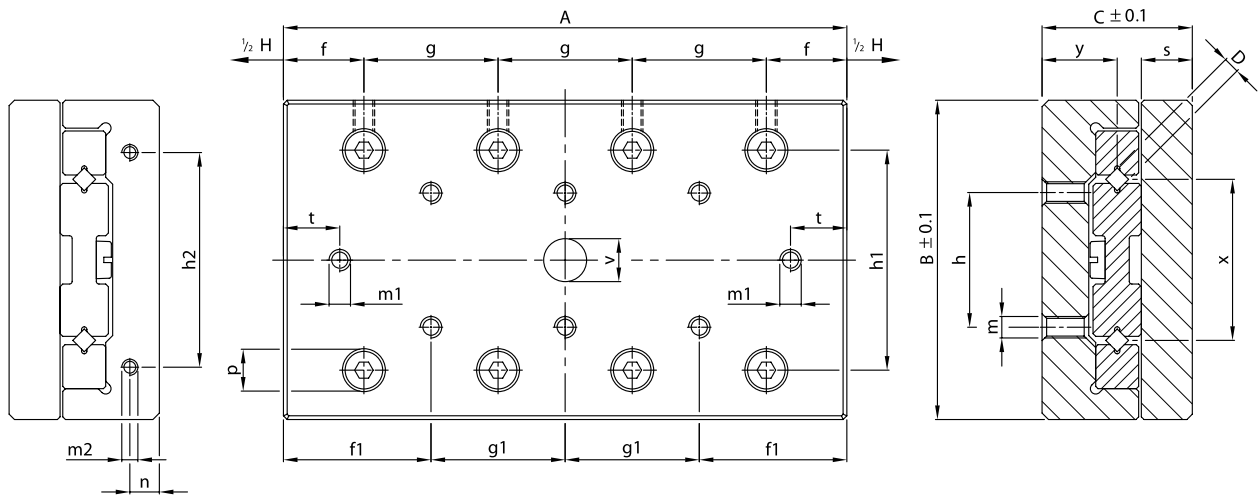

Please see drawings on page 112-113 for configuration of mounting holes in the slide base.

Type	Main dimensions				Stroke H												
	A	B	C	D	RTN	RTL	f	f1	g	g1	h	h1	h2	m	m1	m2	
RT-1520	25				10	-			1x10	-							
RT-1530	35				15	20			2x10	1x10							
RT-1540	45				20	30			3x10	2x10							
RT-1550	55				25	40			4x10	3x10							
RT-1560	65	29.6	17	1.5	30	50	7.5	12.5	5x10	4x10	10	18.4	12	M2.5	M2	M2	
RT-1570	75				35	60			6x10	5x10							
RT-1580	85				40	70			7x10	6x10							
RT-1590	95				45	80			8x10	7x10							
RT-15100	105				50	90			9x10	8x10							
RT-2030	35				15	-			1x15	-							
RT-2045	50				22	30			2x15	1x15							
RT-2060	65				30	45			3x15	2x15							
RT-2075	80				37	60			4x15	3x15							
RT-2090	95	39.6	21	2	45	75	10	17.5	5x15	4x15	15	25	16	M3	M2.5	M2	
RT-2105	110				52	90			6x15	5x15							
RT-2120	125				60	105			7x15	6x15							
RT-2135	140				67	120			8x15	7x15							
RT-2150	155				75	135			9x15	8x15							
RT-3050	55				-	30			1x25	-							
RT-3075	80				37	55			2x25	1x25							
RT-3100	105				50	80			3x25	2x25							
RT-3125	130				62	105			4x25	3x25							
RT-3150	155				75	130			5x25	4x25							
RT-3175	180	59.5	28	3	87	155	15	27.5	6x25	5x25	25	41	40	M4	M4	M3	
RT-3200	205				100	180			7x25	6x25							
RT-3250	255				125	230			9x25	8x25							
RT-3300	305				150	280			11x25	10x25							
RT-3350	355				175	330			13x25	12x25							
RT-3400	405				200	380			15x25	14x25							

Bold = Short lead time item

Regular = Long lead time item - please ask us about prices and lead times

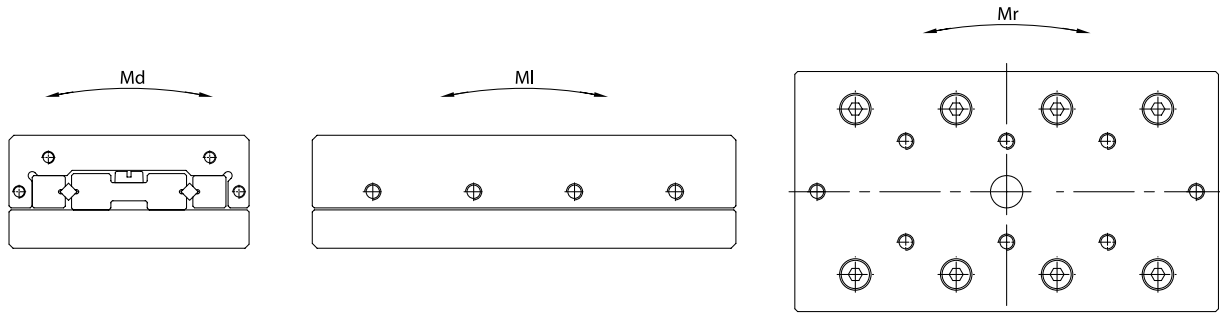

n	p	s	t	v	x	y	C _{dyn} in N		Weight (kg)	Md in Nm		MI in Nm		Mr in Nm	
							RTN	RTL		RTN	RTL	RTN	RTL	RTN	RTL
2.5	4.6	6	2.44	4.5	13.5	8.75	260	-	0.10	1.4	-	1.2	-	1.5	-
			364				312	0.12	2.1	2.1	2.5	1.9	1.9	1.7	
			520				416	0.16	3.5	2.8	4.4	3.1	2.6	2.1	
			624				520	0.19	4.2	3.5	5.6	4.4	3.1	2.6	
			780				572	0.23	4.9	3.5	7.5	5.0	4.0	2.9	
			884				676	0.27	5.6	4.2	8.7	6.2	4.6	3.4	
			1040				780	0.30	7.0	4.9	10.6	7.5	5.5	4.0	
			1144				832	0.34	7.7	5.6	11.9	8.1	6.1	4.3	
			1300				936	0.37	8.4	6.3	13.7	9.4	7.0	4.9	
3.4	6.3	7	5.5	5.5	18	10.75	430	-	0.19	3.1	-	2.8	-	3.4	-
							688	602	0.28	6.2	4.6	6.9	5.5	4.6	4.1
							946	774	0.38	7.7	6.2	11.0	8.3	6.3	5.2
							1204	946	0.47	10.8	7.7	15.1	11.0	8.2	6.3
							1376	1118	0.56	12.4	9.3	17.9	13.8	9.5	7.5
							1634	1290	0.65	13.9	10.8	22.0	16.5	11.4	8.8
							1892	1376	0.75	17.0	12.4	26.1	17.9	13.4	9.5
							2150	1548	0.84	18.6	13.9	30.3	20.6	15.4	10.8
							2408	1720	0.93	21.7	15.5	34.4	23.4	17.5	12.1
5.5	7.8	9.5	5.5	8	30	14	-	952	0.64	-	12.2	-	10.9	-	5.4
							1496	1224	0.94	20.4	16.3	21.8	16.3	13.6	11.5
							2040	1632	1.24	28.6	24.5	32.6	24.5	18.2	14.7
							2448	1904	1.55	36.7	28.6	40.8	29.9	22.0	17.0
							2992	2312	1.86	44.9	32.6	51.7	38.1	27.1	20.7
							3536	2584	2.15	53.0	36.7	62.6	43.5	32.3	23.2
							4080	2992	2.46	61.2	44.9	73.4	51.7	37.6	27.1
							5032	3672	3.06	73.4	53.0	92.5	65.3	47.0	33.6
							6120	4352	3.66	89.8	65.3	114.2	78.9	57.7	40.3
							7072	5032	4.27	106.1	73.4	133.3	92.5	67.1	47.0
							8160	5712	4.87	122.4	85.7	155.0	106.1	77.9	53.7

Units: mm

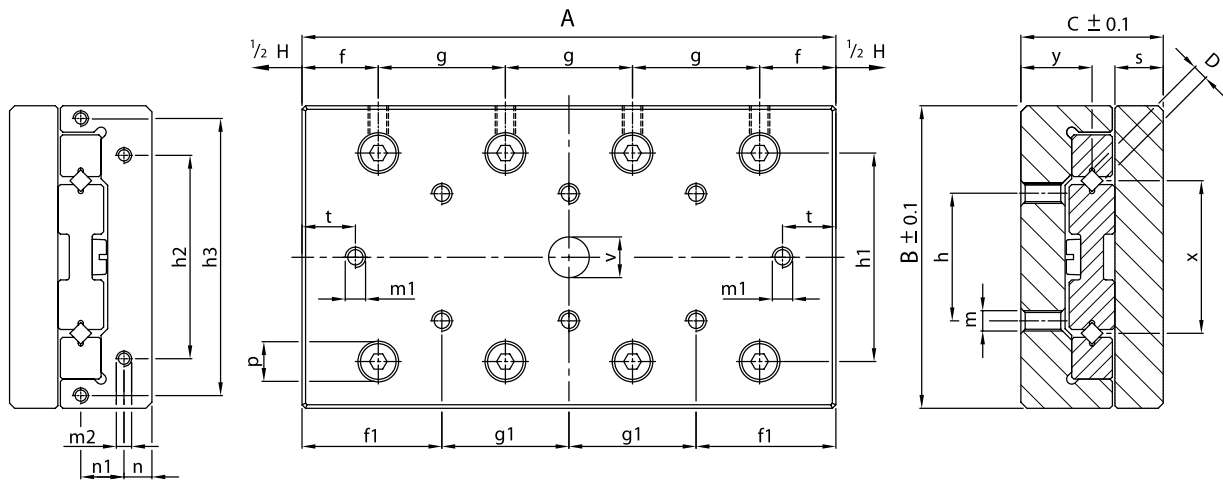

Please see drawings on page 112-113 for configuration of mounting holes in the slide base.

Type	Main dimensions				Stroke H												
	A	B	C	D	RTN	RTL	f	f1	g	g1	h	h1	h2	h3	m	m1	
RT-4080	85				50	-			1x40	-							
RT-4120	125				75	90			2x40	1x40							
RT-4160	165				105	130			3x40	2x40							
RT-4200	205				130	170			4x40	3x40							
RT-4240	245	80	35	4	155	210	22.5	42.5	5x40	4x40	40	53	55	-	M5	M5	
RT-4280	285				185	250			6x40	5x40							
RT-4320	325				210	290			7x40	6x40							
RT-4360	365				235	330			8x40	7x40							
RT-4400	405				265	370			9x40	8x40							
RT-6100	110				50	70			1x50	-							
RT-6150	160				75	120			2x50	1x50							
RT-6200	210				100	170			3x50	2x50							
RT-6250	260				125	220			4x50	3x50							
RT-6300	310				150	270			5x50	4x50							
RT-6350	360	99.5	45	6	175	320	30	55	6x50	5x50	50	65	90	92	M6	M6	
RT-6400	410				200	370			7x50	6x50							
RT-6450	460				225	420			8x50	7x50							
RT-6500	510				250	470			9x50	8x50							
RT-6600	610				300	570			11x50	10x50							
RT-6700	710				350	670			13x50	12x50							
RT-9100	110				50	-	30	55	1x50	-							
RT-9200	210				100	150			1x100	-							
RT-9300	310				150	250			2x100	1x100							
RT-9400	410				200	350			3x100	2x100							
RT-9500	510	148	60	9	250	450	55	105	4x100	3x100	100	104	90	135	M8	M8	
RT-9600	610				300	550			5x100	4x100							
RT-9700	710				350	650			6x100	5x100							
RT-9800	810				400	750			7x100	6x100							
RT-9900	910				450	850			8x100	7x100							
RT-91000	1010				500	950			9x100	8x100							

Bold = Short lead time item

Regular = Long lead time item - please ask us about prices and lead times

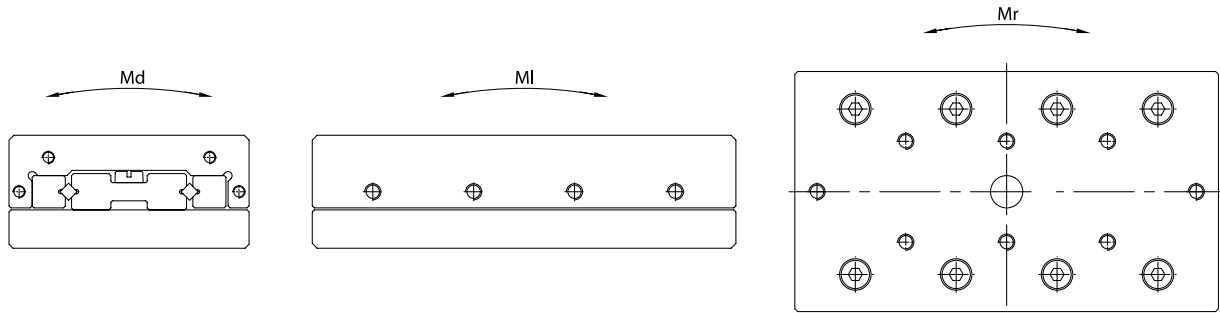

m2	n	n1	p	s	t	v	x	y	C _{dyn} in N		Weight (kg)	Md in Nm		MI in Nm		Mr in Nm	
									RTN	RTL		RTN	RTL	RTN	RTL	RTN	RTL
M3	6.5	-	10	10.5	9	9.5	40	18.5	1855	-	1.70	31.8	-	29.7	-	25.9	-
									2915	2650	2.50	53.0	53.0	59.4	51.9	36.5	33.5
									3710	3445	3.30	74.2	63.6	81.6	74.2	46.0	42.7
									4770	4240	4.10	95.4	84.8	111.3	96.5	59.6	52.7
									5830	4770	4.90	116.6	95.4	141.0	111.3	73.6	59.6
									6890	5565	5.70	137.8	106.0	170.7	133.6	87.9	70.1
									7950	6360	6.50	159.0	127.2	200.3	155.8	102.4	80.7
									9010	7155	7.30	180.2	137.8	230.0	178.1	116.9	91.5
									9805	7950	8.10	190.8	159.0	252.3	200.3	127.9	102.4
M4	8	15	11	14	10	11	46	23	4320	3780	3.30	97.2	72.9	97.2	77.8	68.7	62.2
									6480	5400	4.84	145.8	121.5	175.0	136.1	100.1	83.6
									8640	6480	6.37	194.4	145.8	252.7	175.0	135.4	100.1
									10800	8100	7.91	243.0	170.1	330.5	233.3	172.2	126.4
									13500	9720	9.44	291.6	218.7	427.7	291.6	219.3	153.7
									15660	11340	11.00	340.2	243.0	505.4	349.9	257.4	181.6
									17820	12420	12.54	388.8	267.3	583.2	388.8	295.6	200.4
									19980	14040	14.07	437.4	315.9	661.0	447.1	334.0	228.8
									22140	15660	15.60	486.0	340.2	738.7	505.4	372.5	257.4
									27000	18900	18.65	607.5	413.1	913.7	622.1	459.4	314.8
31320	21600	21.71	704.7	486.0	1069.2	719.3	536.8	362.9									
M4	11	20	14	17	17	14	78	31	6750	-	6.50	210.6	-	151.2	-	223.8	-
									13500	10800	12.64	526.5	421.2	529.2	378.0	338.2	283.0
									21600	16200	18.86	842.4	631.8	982.8	680.4	534.6	400.1
									28350	21600	25.08	1053.0	842.4	1360.8	982.8	712.2	534.6
									35100	25650	31.20	1368.9	947.7	1738.8	1209.6	894.5	640.4
									43200	31050	37.41	1684.8	1158.3	2192.4	1512.0	1116.2	784.8
									49950	35100	43.53	1895.4	1368.9	2570.4	1738.8	1302.3	894.5
									56700	40500	49.75	2211.3	1579.5	2948.4	2041.2	1489.2	1042.1
									64800	44550	55.96	2527.2	1684.8	3402.0	2268.0	1714.0	1153.4
									71550	49950	62.08	2737.8	1895.4	3780.0	2570.4	1901.7	1302.3

Units: mm

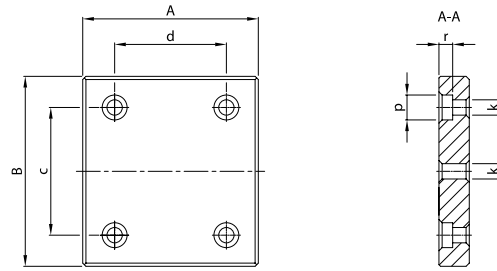

Fig. 1

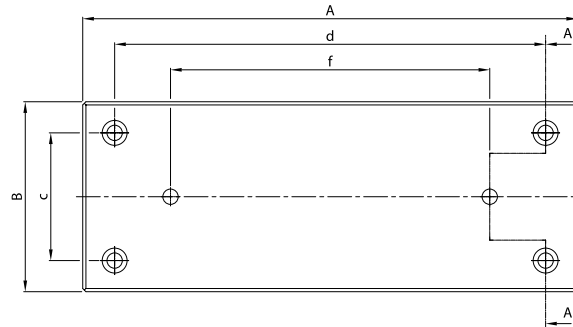

Fig. 2

Configuration of mounting holes in the slide base

Type	A	B	c	d	e	f	g	k	p	r	Fig.
RT-1520	25			17	-	-	-				1
RT-1530	35			27	-	-	-				1
RT-1540	45			37	-	-	-				1
RT-1550	55			47	-	25	-				2
RT-1560	65	29.6	22	57	-	30	-	3	5	2.5	2
RT-1570	75			67	-	35	-				2
RT-1580	85			77	-	40	-				2
RT-1590	95			87	-	45	-				2
RT-15100	105			97	-	50	-				2
RT-2030	35			25	-	-	-				1
RT-2045	50			40	-	-	-				1
RT-2060	65			55	-	-	-				1
RT-2075	80			70	-	-	-				1
RT-2090	95			85	-	45	-				2
RT-2105	110	39.6	30	100	-	50	-	3.8	6.3	3.3	2
RT-2120	125			115	-	30	-				2
RT-2135	140			130	-	40	-				2
RT-2150	155			145	-	40	-				2
RT-3050	55			35	-	-	-				1
RT-3075	80			60	-	-	-				1
RT-3100	105			85	-	-	-				1
RT-3125	130			110	-	-	-				1
RT-3150	155			135	-	75	-				2
RT-3175	180	59.5	40	160	-	86	-	4.8	7.8	4.3	2
RT-3200	205			185	-	55	-				2
RT-3250	255			235	145	55	-				3
RT-3300	305			285	165	65	-				3
RT-3350	355			335	195	75	-				3
RT-3400	405			385	225	85	-				3

Bold = Short lead time item

Regular = Long lead time item - please ask us about prices and lead times

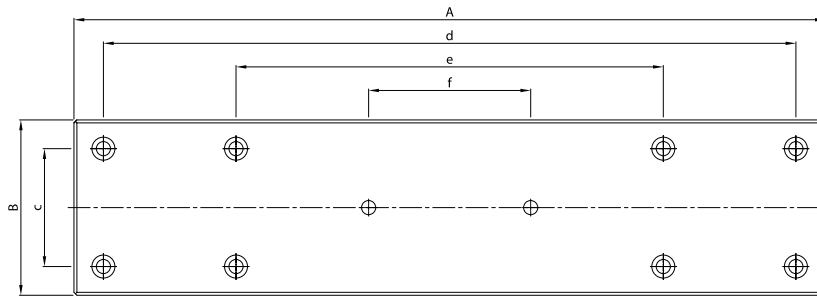

Fig. 3

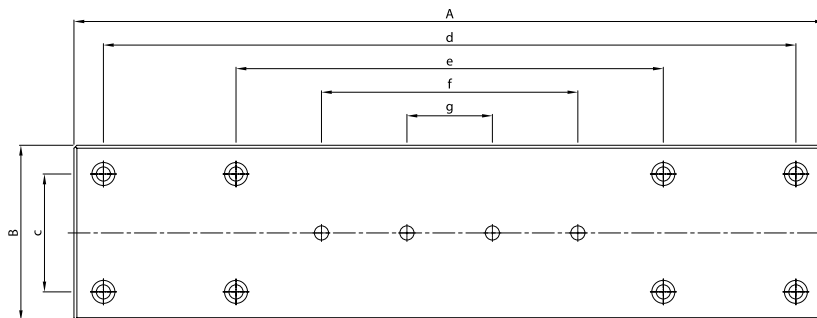

Fig. 4

Type	A	B	c	d	e	f	g	k	p	r	Fig.
RT-4080	85			65	-	-					1
RT-4120	125			105	-	-					1
RT-4160	165			145	-	-					1
RT-4200	205			185	-	105					2
RT-4240	245	80	55	225	-	145	-	5.5	10	5.4	2
RT-4280	285			265	-	185					2
RT-4320	325			305	145	225					3
RT-4360	365			345	185	265					3
RT-4400	405			385	225	305					3
RT-6100	110			90	-	-					1
RT-6150	160			140	-	-					1
RT-6200	210			190	-	100					2
RT-6250	260			240	-	120					2
RT-6300	310			290	-	150					2
RT-6350	360	99.5	60	340	200	80	-	6.8	11	6.3	3
RT-6400	410			390	230	90					3
RT-6450	460			440	260	100					3
RT-6500	510			490	290	110					3
RT-6600	610			590	350	210					4
RT-6700	710			690	410	250					4
RT-9100	110			80	-	-					1
RT-9200	210			100	-	-					1
RT-9300	310			200	-	-					1
RT-9400	410			300	-	180					2
RT-9500	510	148	90	400	-	240	-	9	14	8.7	2
RT-9600	610			500	340	120					3
RT-9700	710			600	400	140					3
RT-9800	810			700	460	280					4
RT-9900	910			800	520	320					4
RT-91000	1010			900	600	360					4

Units: mm

RUNNING ACCURACIES AND TOLERANCES

The table below shows the accuracies for different types of PM slides. Accuracies are checked with the slides being in unloaded horizontal position. Values displayed below are also applicable to 2-axis combinations. Where relevant, please refer to the appropriate stroke lengths.

In more complex cases, for instance involving a combination of axes, please contact us for expert support. On request we are able to deliver the precision slides provided with a certificate of compliance, on the basis of measurement by laser accuracy equipment. Special higher accuracy grade slides are available on request.

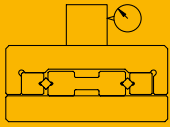
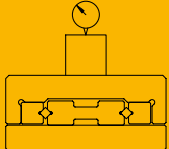
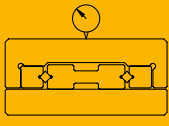
Type	A in mm	 Straight line accuracy in μm over travel length on the side	 Flatness accuracy in μm over travel length on the top	 Parallelism in μm , neutral position on slide top
RT (RTN/RTL)	25-50	2	2	5
	55-95	3	2	6
	105-155	4	3	7
	160-305	4	3	8
	310-510	4	4	10
	510-710	5	4	13
	810-1010	5	5	15
RTA (RTNA/RTLA) Aluminum	25-50	2	2	5
	55-95	3	2	5
	105-155	4	3	8
	160-305	4	3	10
	310-510	4	4	15
	510-710	5	4	20
	810-1010	5	5	25
RTNG	52-91	2	2	5
	106-166	3	2	6
	171-314	3	3	7
	317-517	4	3	10
	524-817	4	4	13
	824-1028	5	5	15
RTS	25-45	3	3	2
	55-95	4	4	4
	105-155	5	5	5
PMM and PMMR	15-30	3	4	5
	35-50	4	4	6
	60-80	5	6	8

Tolerance on the height $+0.03\text{ mm} / -0.1\text{ mm}$ | Optional: Slides can be supplied with a height tolerance of $\pm 0.01\text{ mm}$

1. STRAIGHT LINE ACCURACY: this is the amount of error deviance from the ideal straight line of travel in the vertical plane.

2. FLATNESS ACCURACY: this is the amount of error deviance from the ideal straight line of travel in the horizontal plane.

PARALLISM IN μm , NEUTRAL POSITION ON SLIDE TOP: the parallellism of the slide surfaces occurs unloaded on a flat, horizontal surface in zero-position.

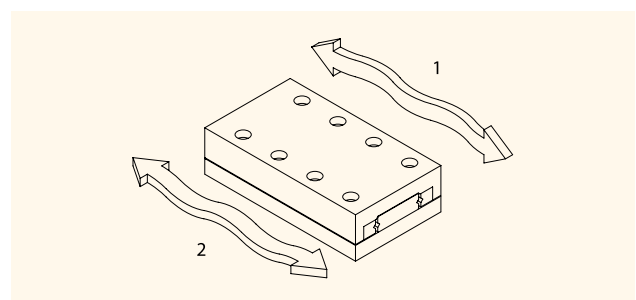



SAVE TIME!

Direct access to the 3D CAD models of our standard products

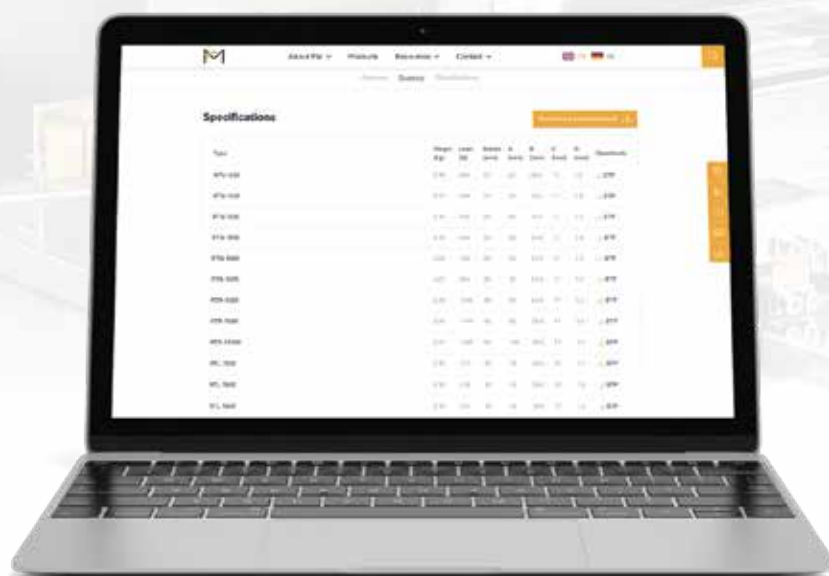

www.PM.NL

PM RESEARCH AND PRODUCTION FACILITIES



PM B.V.

Galileistraat 2
NL-7701 SK, Dedemsvaart
The Netherlands

Tel: +31 523 61 22 58
info@PM.nl

www.PM.nl

2020