

SG series Standardized Precision Ball Screws

Precision Ball Screws which are accuracy C3, C5 and have machined shaft end at fixed side in advance are available. Short delivery is available by machining supported end in accordance with customer's request.

Combination of Shaft nominal dia. & Lead

Unit:mm

Lead \ Shaft dia.	0.5	1	2	2.5	4	5	6	8	10	12	15	20
3	A207	A208										
4		A209	A210									
5					A211							
6		A212	A213	A214			A215		A216			
8		A217	A218	A219	A220	A221		A222		A223		
10		A224	A225		A226	A227			A228		A229	
12			A230						A231			
14			A232		A233							
15						A234			A235			A236

Note 1) The number in a table : showing a page in this catalogue.

Accuracy Grade & Axial play

Accuracy grade of SG series (Standardized Precision Ball Screws) are based on C3 and C5(JIS B 1192-3). According to accuracy grade, Axial play 0(Preload : C3) and 0.005mm or less (C5) are in stock.

Material & Surface hardness

SG series (Standardized Precision Ball Screws) consists of Shaft and Nut materials SCM415 (Carburizing and quenching) and Surface hardness is HRC58~62.

Lubrication

SG series (Standardized Precision Ball Screws) without end-journal machining will be applied with anti-rust oil for rust prevention.

Anti-rust oil does not have lubricating function so that please apply Grease or lubrication oil when using the Ball Screws.

If there is no specific instruction, KSS would recommend our original Grease (MSG No.2) as standard lubricant. Please feel free to contact us.

Customized products

It will be a customized product other than the above. Please ask KSS.

Model number notation

Please use model number below when additional end-journal machining is requested.

SG **04** **01** **-** **046** **R** **085** **C3** **B** **1** **X**

① ② ③ ④ ⑤ ⑥ ⑦ ⑧ ⑨ ⑩

- ① Ball Screws Series No.
- ② Screw Shaft nominal diameter(mm)
- ③ Lead(mm)
- ④ Screw thread length(mm)
(Specify in 1mm unit after end-journal machining)
- ⑤ Thread direction(R=Right-hand)
- ⑥ Screw Shaft total length(mm)
(Specify in 1mm unit)
- ⑦ Accuracy grade(C3 or C5)
- ⑧ Shaft supported end profile
Refer to Fig. A-22 below : A-type, B-type, C-type, D-type(other)
- ⑨ Anti-rust oil or Lubricant
0 : KSS grease (MSG No.2)
1 : Anti-rust oil(Non Ruster PZ2)
2 : Multemp PS2 grease
3 : Other
- ⑩ Nut Flange direction (Refer to Fig. A-23 below)

Fig. A-22 : Shaft supported end profile

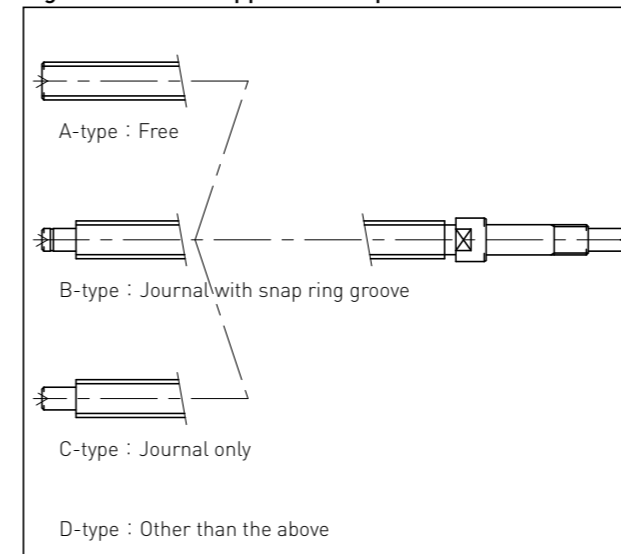
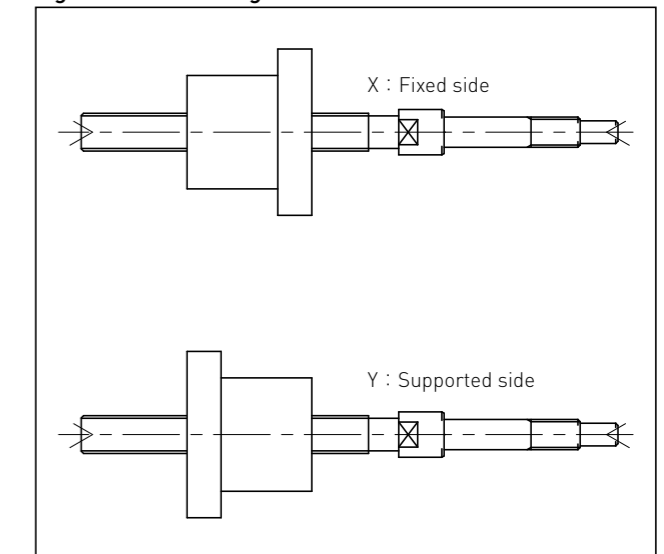

Fig. A-23 : Nut Flange direction



Note

- 1) The detail of end-journal dimension for each size is shown from next page.
- 2) KSS does not make additional Nut machining.
- 3) The specification is subject to change without notice.
- 4) If the other configuration except (A,B,C) is requested, please contact KSS.

SG0300.5

Shaft dia. $\phi 3$ Lead 0.5mm

C3

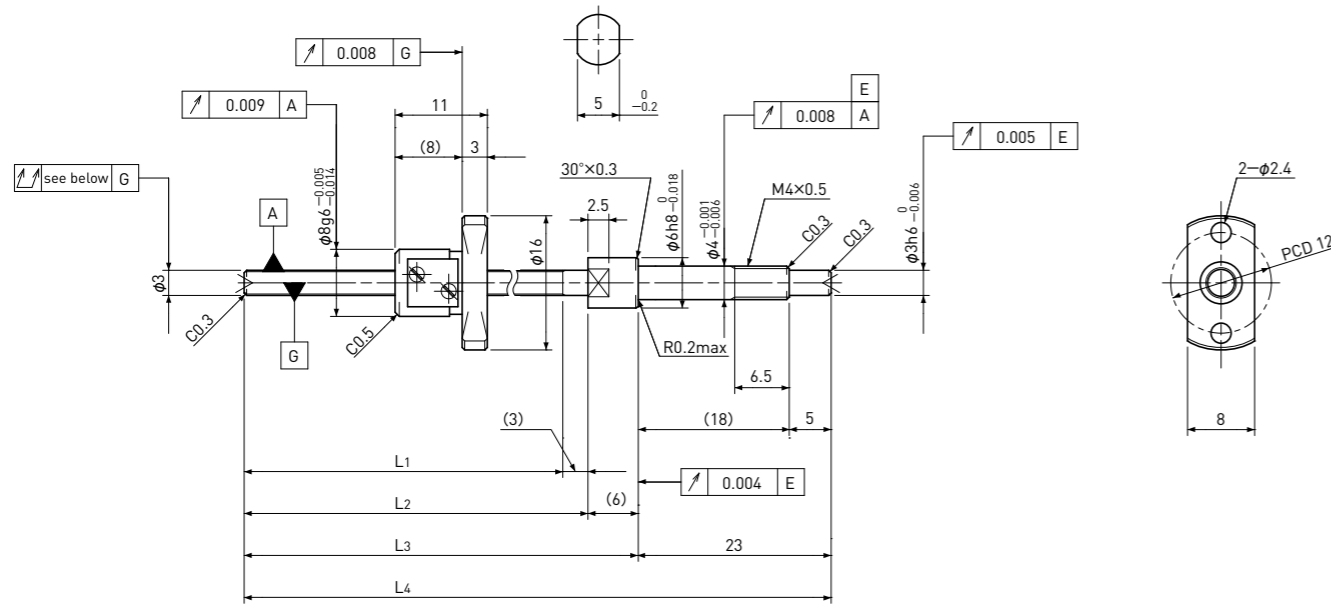

Unit : mm

Ball Screw Specifications		Supported-side end-journal profile							
Ball size	$\phi 0.4$	A-type							
Number of thread	1								
Thread direction	Right								
Shaft root dia.	$\phi 2.6$	L5: Thread length after end-journal machining. L6: Total length after end-journal machining.							
Number of circuit	2.7 × 1	<table border="1"> <thead> <tr> <th>Support-unit Recommendation</th> <th>Supported-side</th> <th>Fixed-side</th> </tr> </thead> <tbody> <tr> <td></td> <td>—</td> <td>MSU-4C/4G</td> </tr> </tbody> </table>		Support-unit Recommendation	Supported-side	Fixed-side		—	MSU-4C/4G
Support-unit Recommendation	Supported-side	Fixed-side							
	—	MSU-4C/4G							
Shaft, Nut material	SCM415H	D-type : Other than the above.							
Surface hardness	HRC58~62 (Thread area)								
Anti-rust treatment	Anti-rust oil								

Unit : mm

Ball Screw Model	Travel	Grade	Shaft length				Lead accuracy		Total Run-out	Axial play	Preload Torque Nm	Basic Load Rating N	
			L1	L2	L3	L4	Travel deviation e_p	Variation V_u				Dynamic C_a	Static C_oa
SG0300.5-038R070C3	25	C3	38	41	47	70	± 0.008	0.008	0.025	~0.005	—	150	220

Note) Please refer to page A206 for order code of end-journal machining.

SG0301

Shaft dia. $\phi 3$ Lead 1mm

C3

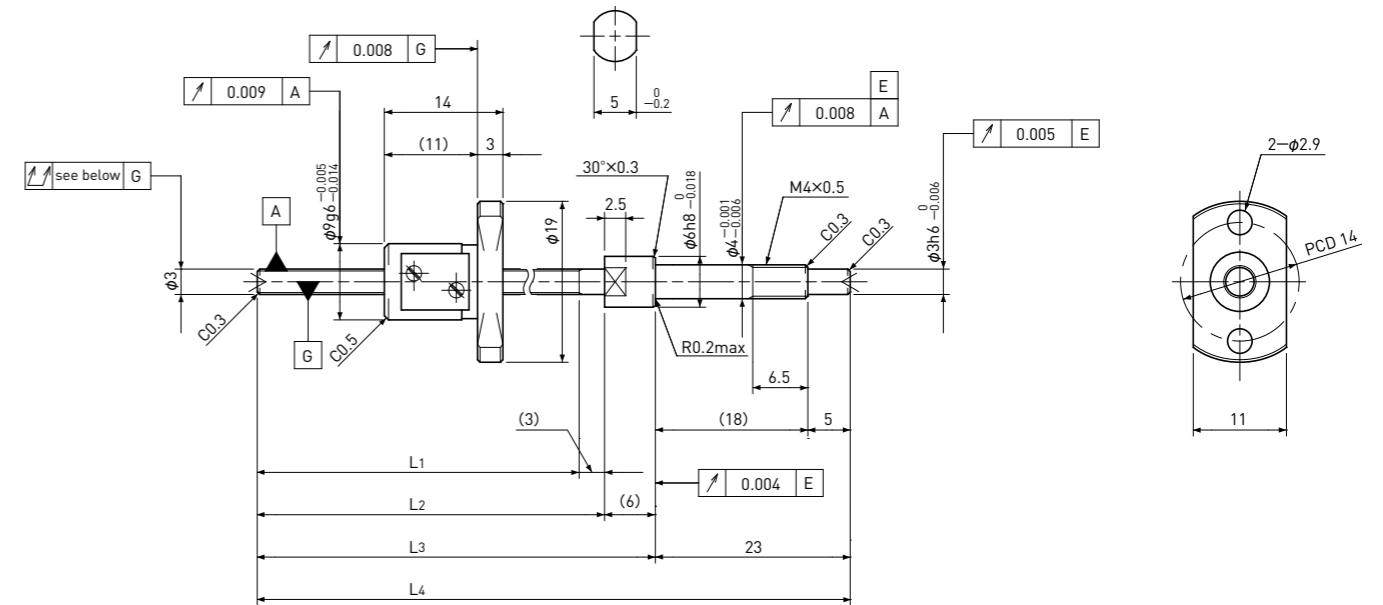

Unit : mm

Ball Screw Specifications		Supported-side end-journal profile							
Ball size	$\phi 0.6$	A-type							
Number of thread	1								
Thread direction	Right								
Shaft root dia.	$\phi 2.4$	L5: Thread length after end-journal machining. L6: Total length after end-journal machining.							
Number of circuit	3.7 × 1	<table border="1"> <thead> <tr> <th>Support-unit Recommendation</th> <th>Supported-side</th> <th>Fixed-side</th> </tr> </thead> <tbody> <tr> <td></td> <td>—</td> <td>MSU-4C/4G</td> </tr> </tbody> </table>		Support-unit Recommendation	Supported-side	Fixed-side		—	MSU-4C/4G
Support-unit Recommendation	Supported-side	Fixed-side							
	—	MSU-4C/4G							
Shaft, Nut material	SCM415H	D-type : Other than the above.							
Surface hardness	HRC58~62 (Thread area)								
Anti-rust treatment	Anti-rust oil								

D-type : Other than the above.

Unit : mm

Ball Screw Model	Travel	Grade	Shaft length				Lead accuracy		Total Run-out	Axial play	Preload Torque Nm	Basic Load Rating N	
			L1	L2	L3	L4	Travel deviation e_p	Variation V_u				Dynamic C_a	Static C_oa
SG0301-038R070C3	20	C3	38	41	47	70	± 0.008	0.008	0.025	~0.005	—	330	440

Note) Please refer to page A206 for order code of end-journal machining.

Standard products in stock SG series

SG0401 | Shaft dia. $\phi 4$ Lead 1mm | **C3&C5**

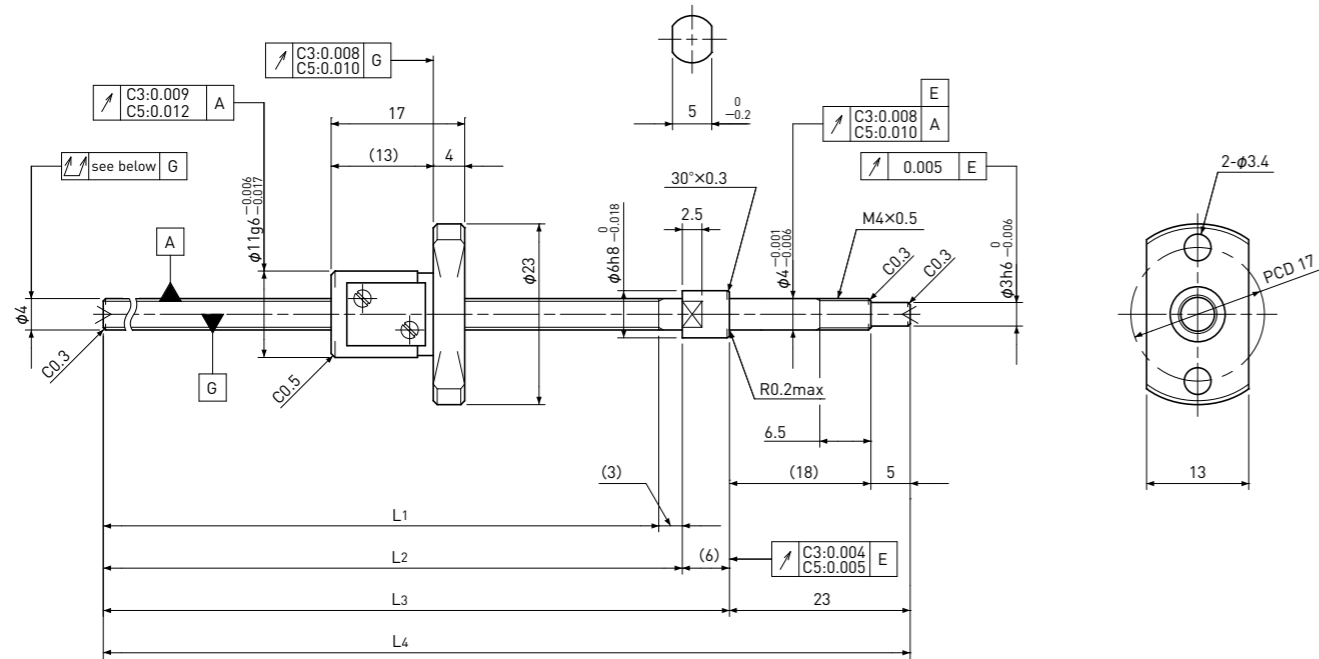

Standard products in stock SG series

SG0402 | Shaft dia. $\phi 4$ Lead 2mm | **C3**

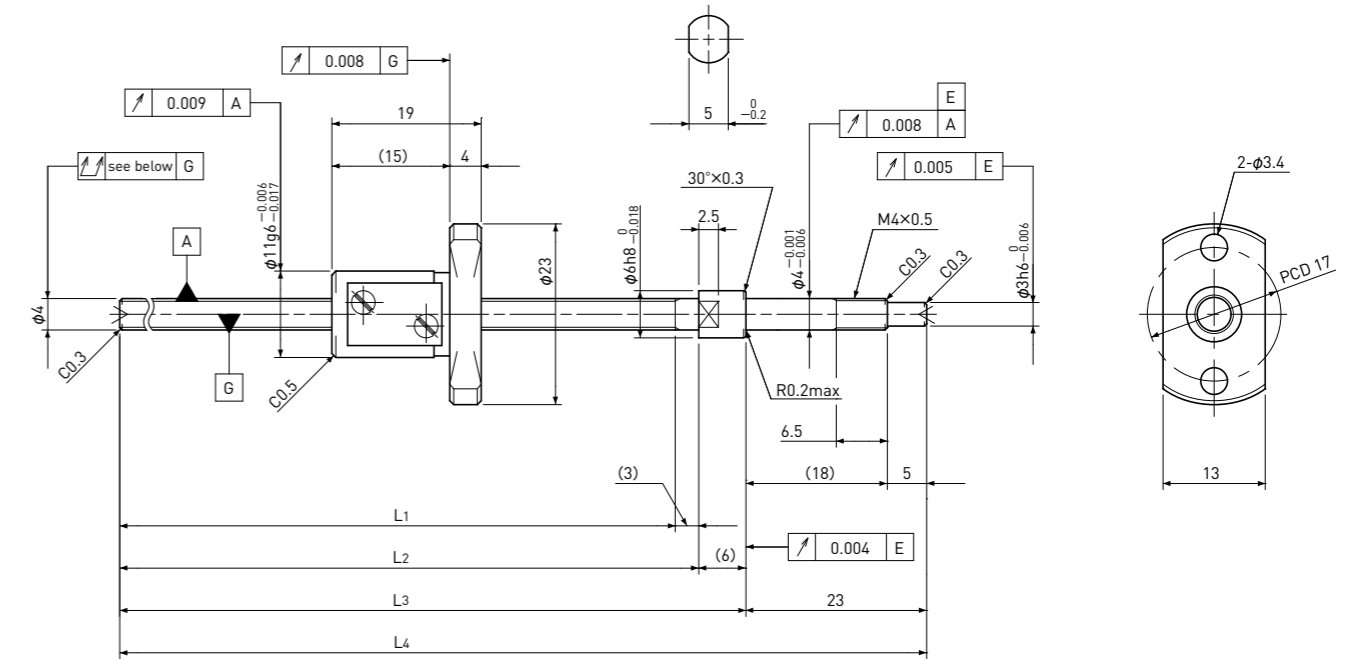

Ball Screw Specifications		Supported-side end-journal profile		
Ball size	$\phi 0.8$	A-type	B-type	C-type
Number of thread	1			
Thread direction	Right	<p>L5: Thread length after end-journal machining. L6: Total length after end-journal machining.</p>		
Shaft root dia.	$\phi 3.3$	<p>Support-unit Recommendation</p> <p>Supported-side : MSU-4CS/4GS Fixed-side : MSU-4C/4G</p>		
Number of circuit	3.7 × 1	<p>D-type : Other than the above.</p>		
Shaft, Nut material	SCM415H			
Surface hardness	HRC58~62 (Thread area)			
Anti-rust treatment	Anti-rust oil			

Unit: mm

Ball Screw Model	Travel	Grade	Shaft length				Lead accuracy		Total Run-out	Axial play	Preload Torque Nm	Basic Load Rating N	
			L1	L2	L3	L4	Travel deviation e_p	Variation V_u				Dynamic C_a	Static C_oa
SG0401-063R095C3	45	C3	63	66	72	95	± 0.008	0.008	0.025	0 Spacer Ball (1:1)	~0.004	350	400
SG0401-083R115C3	65	C3	83	86	92	115	± 0.008	0.008	0.025				
SG0401-103R135C3	85	C3	103	106	112	135	± 0.010	0.008	0.035				
SG0401-063R095C5	45	C5	63	66	72	95	± 0.018	0.018	0.035	~0.005	—	560	790
SG0401-083R115C5	65	C5	83	86	92	115	± 0.018	0.018	0.035				
SG0401-103R135C5	85	C5	103	106	112	135	± 0.020	0.018	0.050				

Note) Please refer to page A206 for order code of end-journal machining.

Ball Screw Specifications		Supported-side end-journal profile		
Ball size	$\phi 0.8$	A-type	B-type	C-type
Number of thread	1			
Thread direction	Right	<p>L5: Thread length after end-journal machining. L6: Total length after end-journal machining.</p>		
Shaft root dia.	$\phi 3.3$	<p>Support-unit Recommendation</p> <p>Supported-side : MSU-4CS/4GS Fixed-side : MSU-4C/4G</p>		
Number of circuit	2.7 × 1	<p>D-type : Other than the above.</p>		
Shaft, Nut material	SCM415H			
Surface hardness	HRC58~62 (Thread area)			
Anti-rust treatment	Anti-rust oil			

Unit: mm

Ball Screw Model	Travel	Grade	Shaft length				Lead accuracy		Total Run-out	Axial play	Preload Torque Nm	Basic Load Rating N	
			L1	L2	L3	L4	Travel deviation e_p	Variation V_u				Dynamic C_a	Static C_oa
SG0402-103R135C3	80	C3	103	106	112	135	± 0.010	0.008	0.035	~0.005	—	420	570

Note) Please refer to page A206 for order code of end-journal machining.

SG0504 | Shaft dia. $\phi 5$ Lead 4mm | C3&C5

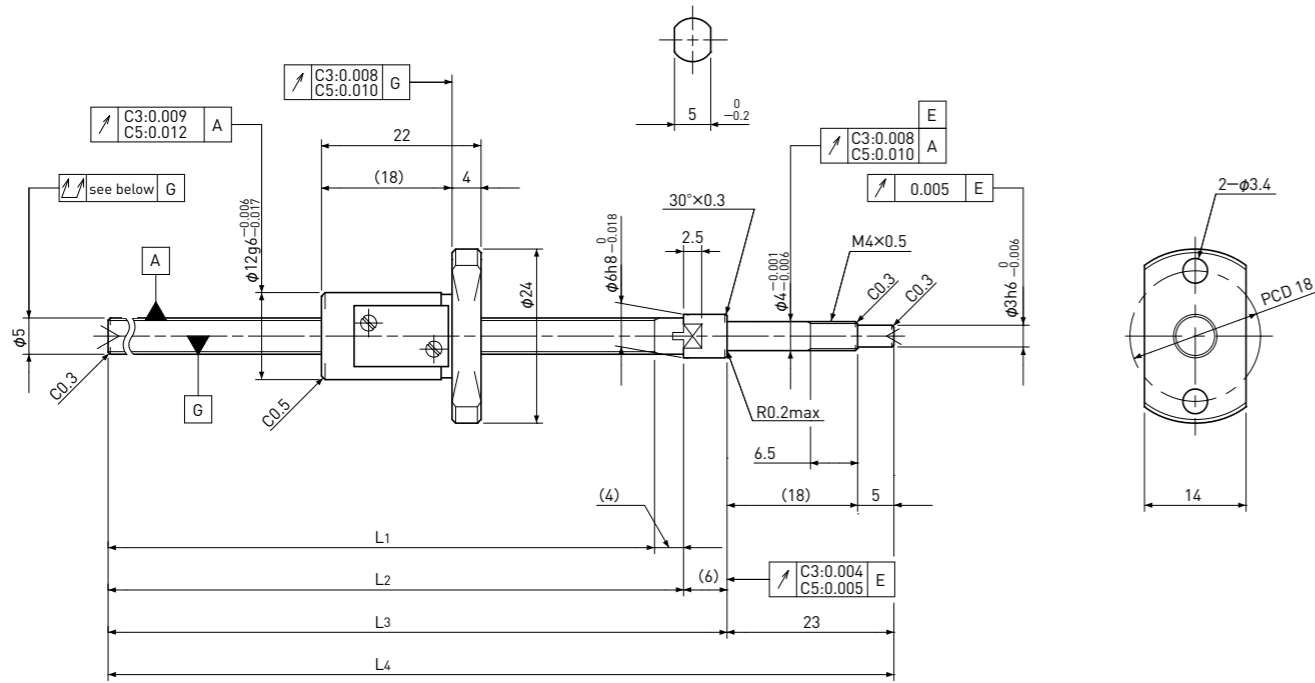

Unit:mm

Ball Screw Specifications	
Ball size	$\phi 0.8$
Number of thread	1
Thread direction	Right
Shaft root dia.	$\phi 4.3$
Number of circuit	2.7 × 1
Shaft, Nut material	SCM415H
Surface hardness	HRC58~62 (Thread area)
Anti-rust treatment	Anti-rust oil

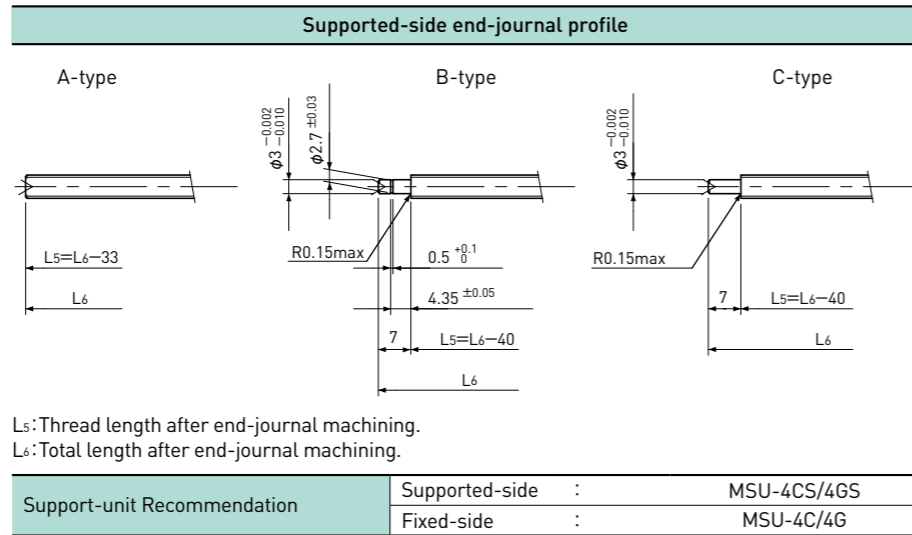

Unit:mm

Ball Screw Model	Travel	Grade	Shaft length				Lead accuracy		Total Run-out	Axial play	Preload Torque Nm	Basic Load Rating N	
			L1	L2	L3	L4	Travel deviation e_p	Variation V_u				Dynamic C_a	Static C_oa
SG0504-062R095C3	40	C3	62	66	72	95	± 0.008	0.008	0.025	0 Spacer Ball (1:1)	~0.005	300	360
SG0504-112R145C3	90	C3	112	116	122	145	± 0.010	0.008	0.035				
SG0504-062R095C5	40	C5	62	66	72	95	± 0.018	0.018	0.035	~0.005	—	470	720
SG0504-112R145C5	90	C5	112	116	122	145	± 0.020	0.018	0.050				

Note) Please refer to page A206 for order code of end-journal machining.

SG0601 | Shaft dia. $\phi 6$ Lead 1mm | C3&C5

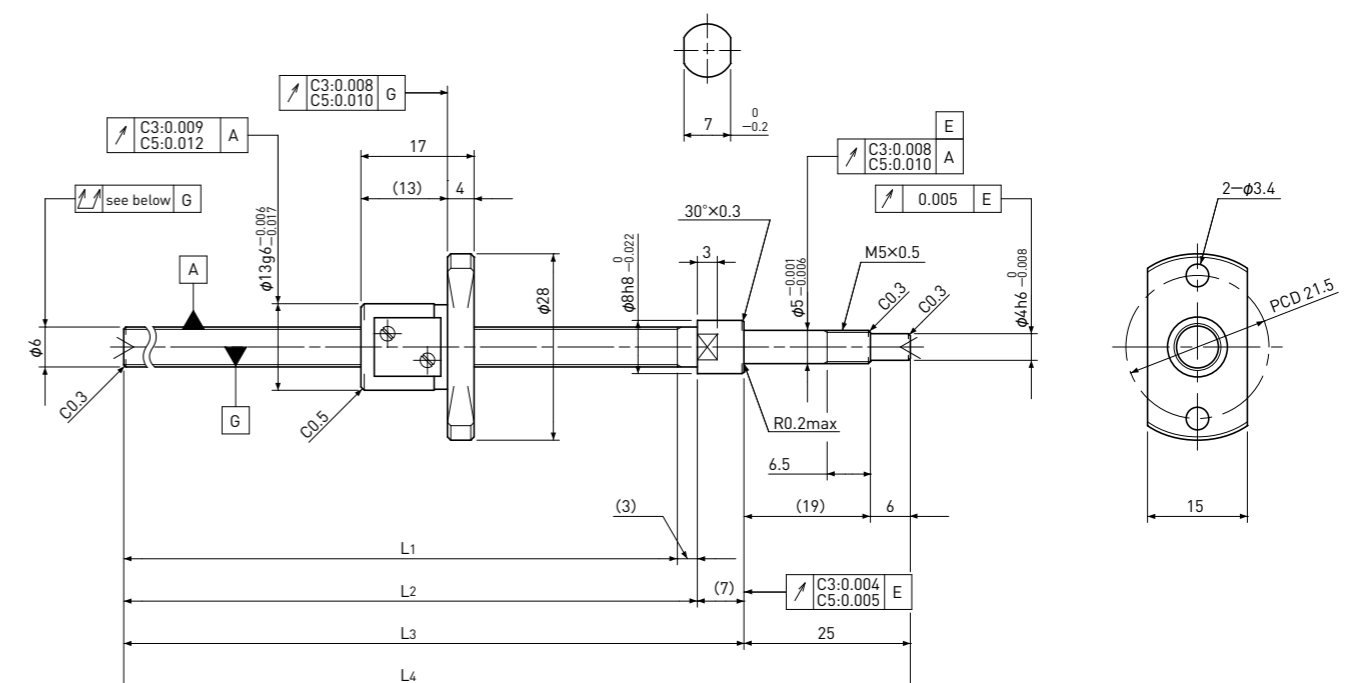

Unit:mm

Ball Screw Specifications	
Ball size	$\phi 0.8$
Number of thread	1
Thread direction	Right
Shaft root dia.	$\phi 5.3$
Number of circuit	3.7 × 1
Shaft, Nut material	SCM415H
Surface hardness	HRC58~62 (Thread area)
Anti-rust treatment	Anti-rust oil

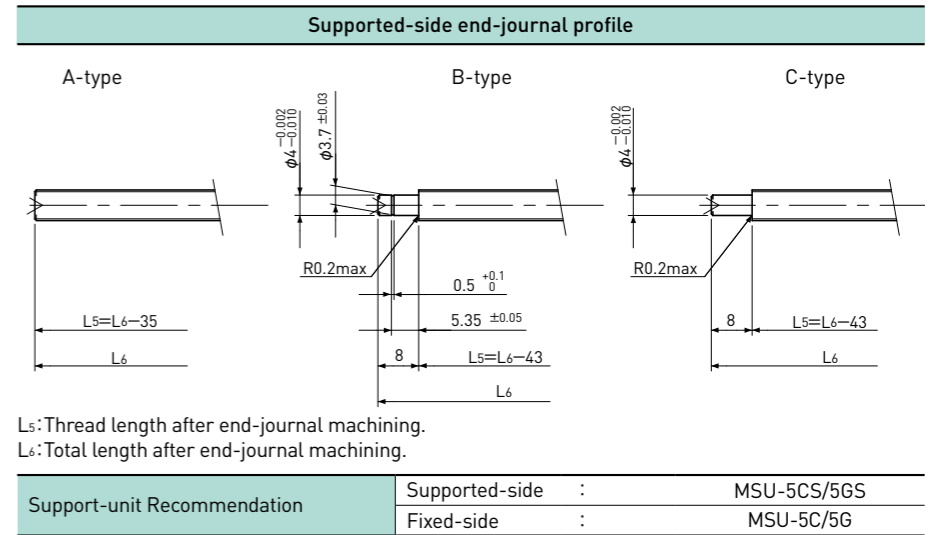

Unit:mm

Ball Screw Model	Travel	Grade	Shaft length				Lead accuracy		Total Run-out	Axial play	Preload Torque Nm	Basic Load Rating N	
			L1	L2	L3	L4	Travel deviation e_p	Variation V_u				Dynamic C_a	Static C_oa
SG0601-085R120C3	65	C3	85	88	95	120	± 0.008	0.008	0.025	0 Spacer Ball (1:1)	~0.006	430	610
SG0601-110R145C3	90	C3	110	113	120	145	± 0.010	0.008	0.035				
SG0601-135R170C3	115	C3	135	138	145	170	± 0.010	0.008	0.035	~0.005	—	680	1200
SG0601-085R120C5	65	C5	85	88	95	120	± 0.018	0.018	0.035				
SG0601-110R145C5	90	C5	110	113	120	145	± 0.020	0.018	0.050				
SG0601-135R170C5	115	C5	135	138	145	170	± 0.020	0.018	0.050				

Note) Please refer to page A206 for order code of end-journal machining.

SG0602 | Shaft dia. $\phi 6$ Lead 2mm | C3&C5

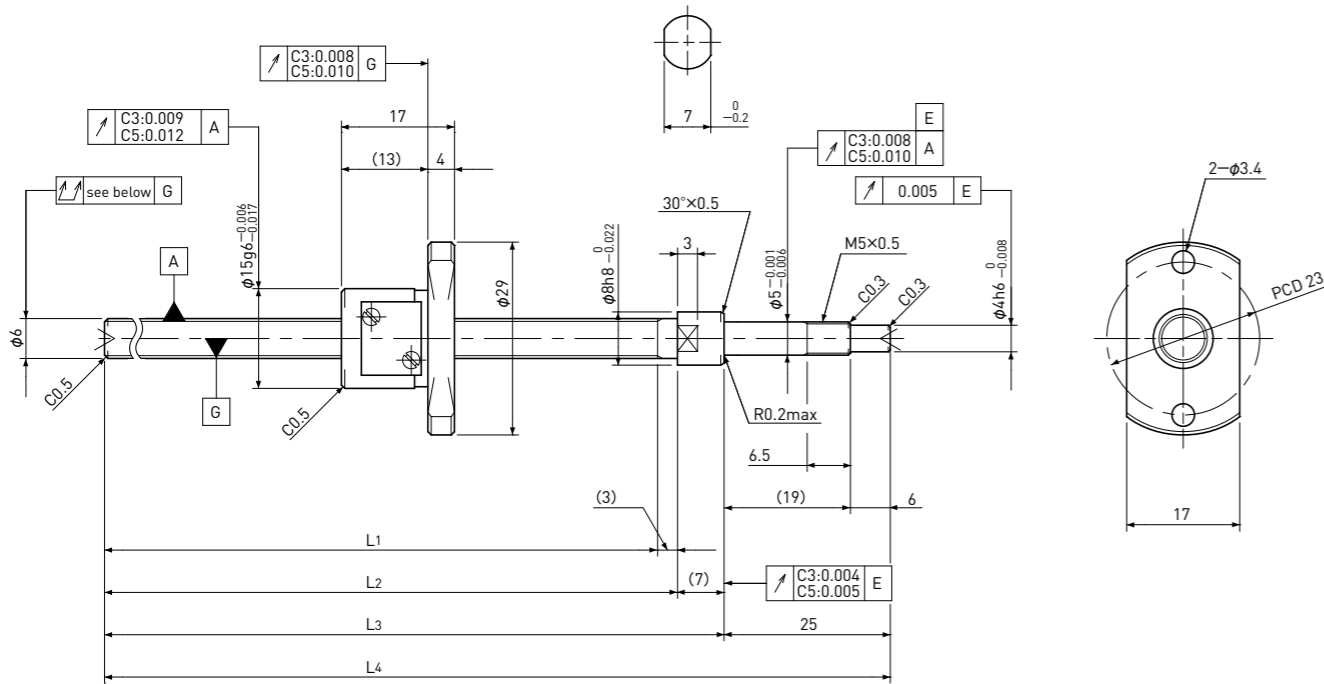

Unit:mm

Ball Screw Specifications	
Ball size	$\phi 1.0$
Number of thread	1
Thread direction	Right
Shaft root dia.	$\phi 5.1$
Number of circuit	2.7 × 1
Shaft, Nut material	SCM415H
Surface hardness	HRC58~62 (Thread area)
Anti-rust treatment	Anti-rust oil

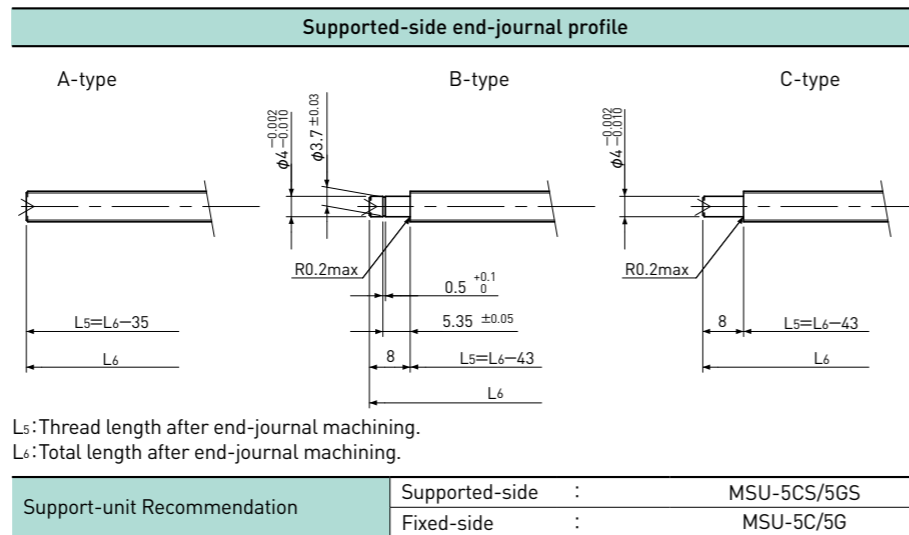

Unit:mm

Ball Screw Model	Travel	Grade	Shaft length				Lead accuracy		Total Run-out	Axial play	Preload Torque Nm	Basic Load Rating N	
			L1	L2	L3	L4	Travel deviation e_p	Variation V_u				Dynamic C_a	Static C_oa
SG0602-085R120C3	65	C3	85	88	95	120	± 0.008	0.008	0.025	0 Spacer Ball (1:1)	0.003~0.007	470	590
SG0602-135R170C3	115	C3	135	138	145	170	± 0.010	0.008	0.035				
SG0602-085R120C5	65	C5	85	88	95	120	± 0.018	0.018	0.035	~0.005	—	750	1200
SG0602-135R170C5	115	C5	135	138	145	170	± 0.020	0.018	0.050				

Note) Please refer to page A206 for order code of end-journal machining.

SG0602.5 | Shaft dia. $\phi 6$ Lead 2.5mm | C3&C5

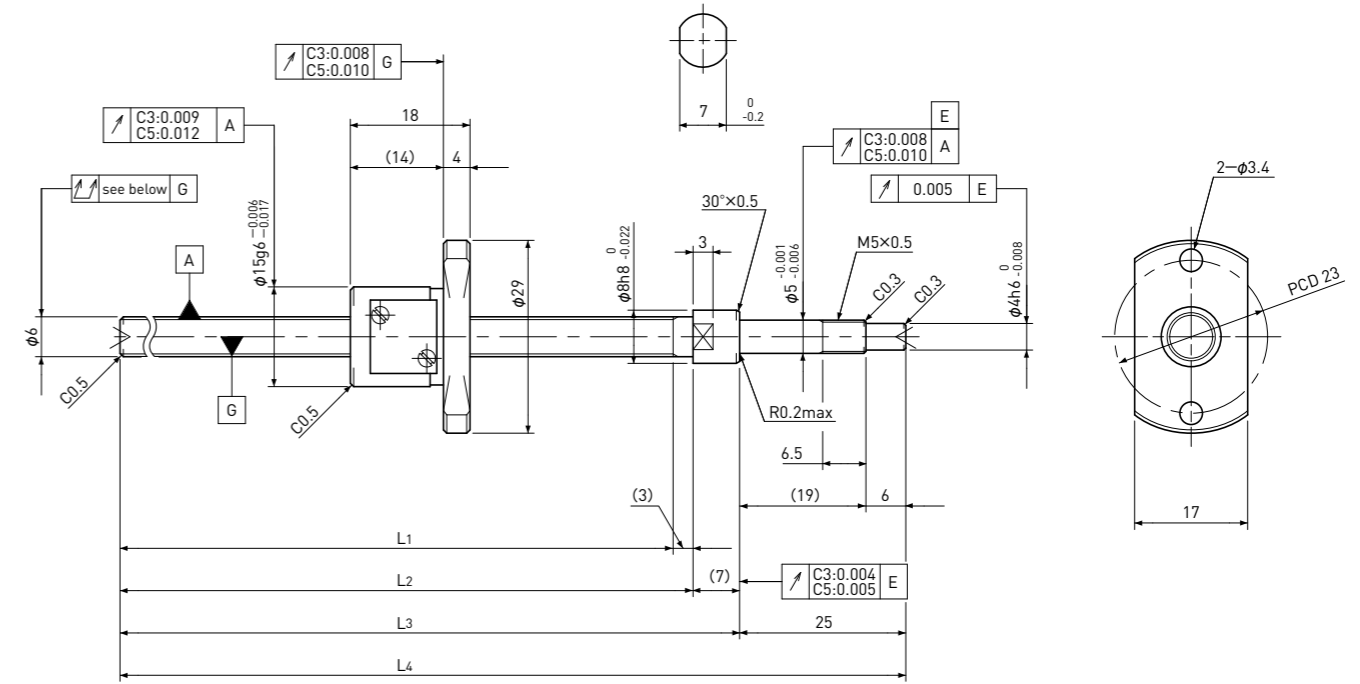

Unit:mm

Ball Screw Specifications	
Ball size	$\phi 1.0$
Number of thread	1
Thread direction	Right
Shaft root dia.	$\phi 5.1$
Number of circuit	2.7 × 1
Shaft, Nut material	SCM415H
Surface hardness	HRC58~62 (Thread area)
Anti-rust treatment	Anti-rust oil

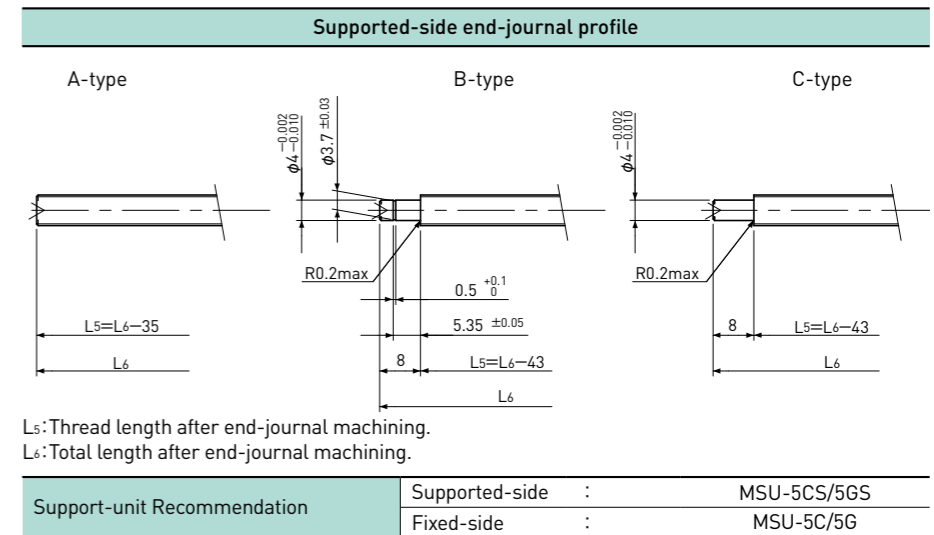

Unit:mm

Ball Screw Model	Travel	Grade	Shaft length				Lead accuracy		Total Run-out	Axial play	Preload Torque Nm	Basic Load Rating N	
			L1	L2	L3	L4	Travel deviation e_p	Variation V_u				Dynamic C_a	Static C_oa
SG0602.5-085R120C3	65	C3	85	88	95	120	± 0.008	0.008	0.025	0 Spacer Ball (1:1)	0.003~0.007	470	590
SG0602.5-135R170C3	115	C3	135	138	145	170	± 0.010	0.008	0.035				
SG0602.5-085R120C5	65	C5	85	88	95	120	± 0.018	0.018	0.035	~0.005	—	750	1200
SG0602.5-135R170C5	115	C5	135	138	145	170	± 0.020	0.018	0.050				

Note) Please refer to page A206 for order code of end-journal machining.

Standard products in stock SG series

SG0606

Shaft dia. $\phi 6$ Lead 6mm

C5

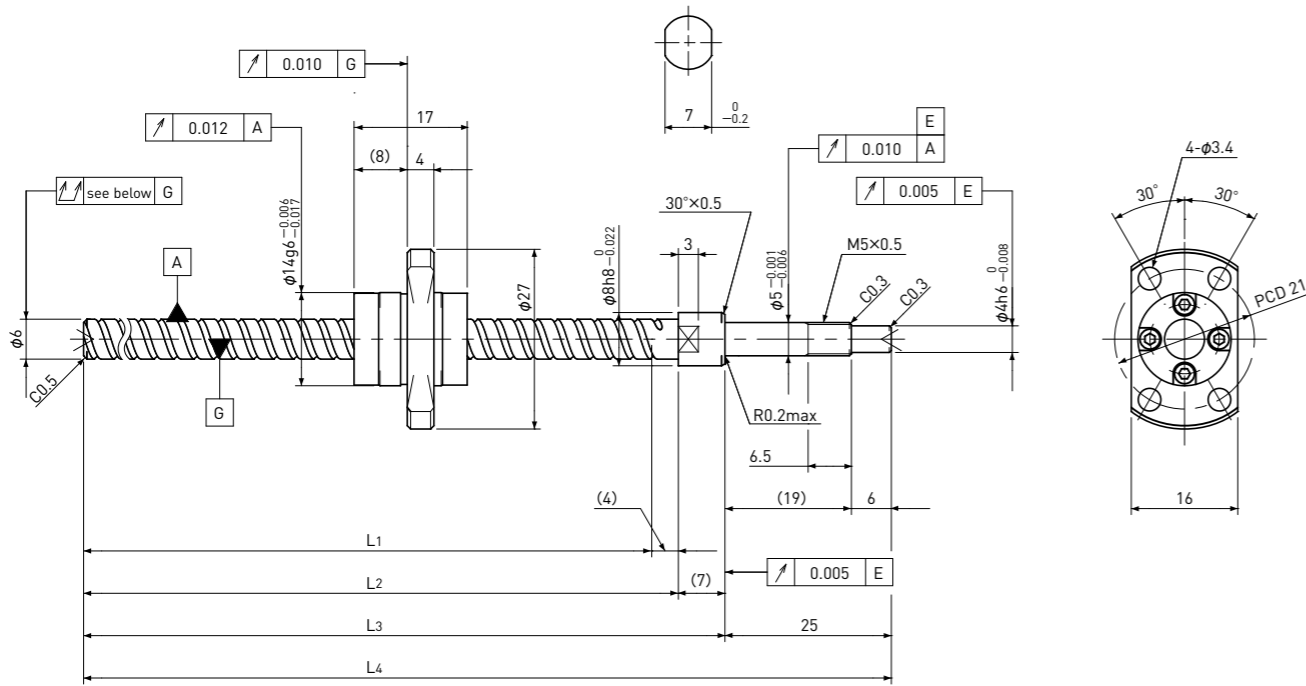

Unit:mm

Ball Screw Specifications	
Ball size	$\phi 1.0$
Number of thread	2
Thread direction	Right
Shaft root dia.	$\phi 5.2$
Number of circuit	1.6 × 2
Shaft, Nut material	SCM415H
Surface hardness	HRC58~62 (Thread area)
Anti-rust treatment	Anti-rust oil

Supported-side end-journal profile		
A-type	B-type	C-type
$L_5=L_6-36$	$L_5=L_6-44$	$L_5=L_6-44$
L ₅ : Thread length after end-journal machining. L ₆ : Total length after end-journal machining.		
Support-unit Recommendation		Supported-side : MSU-5CS/5GS Fixed-side : MSU-5C/5G
D-type : Other than the above.		

Unit:mm

Ball Screw Model	Travel	Grade	Shaft length				Lead accuracy		Total Run-out	Axial play	Preload Torque Nm	Basic Load Rating N	
			L ₁	L ₂	L ₃	L ₄	Travel deviation e _p	Variation V _u				Dynamic Ca	Static Coa
SG0606-084R120C5	65	C5	84	88	95	120	± 0.018	0.018	0.035	~0.005	—	870	1450
SG0606-134R170C5	115	C5	134	138	145	170	± 0.020	0.018	0.050				

Note) Please refer to page A206 for order code of end-journal machining.

Standard products in stock SG series

SG0610

Shaft dia. $\phi 6$ Lead 10mm

C5

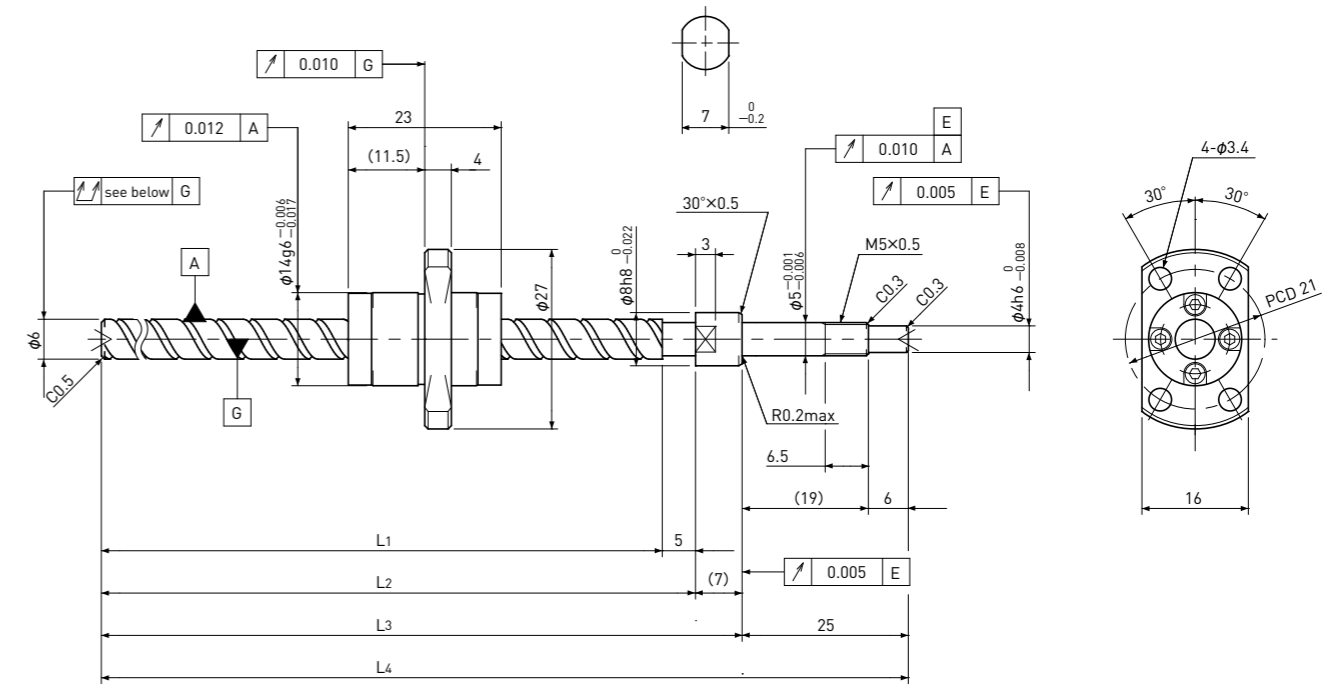

Unit:mm

Ball Screw Specifications	
Ball size	$\phi 1.2$
Number of thread	2
Thread direction	Right
Shaft root dia.	$\phi 5.0$
Number of circuit	1.2 × 2
Shaft, Nut material	SCM415H
Surface hardness	HRC58~62 (Thread area)
Anti-rust treatment	Anti-rust oil

Supported-side end-journal profile		
A-type	B-type	C-type
$L_5=L_6-37$	$L_5=L_6-45$	$L_5=L_6-45$
L ₅ : Thread length after end-journal machining. L ₆ : Total length after end-journal machining.		
Support-unit Recommendation		Supported-side : MSU-5CS/5GS Fixed-side : MSU-5C/5G
D-type : Other than the above.		

Unit:mm

Ball Screw Model	Travel	Grade	Shaft length				Lead accuracy		Total Run-out	Axial play	Preload Torque Nm	Basic Load Rating N	
			L ₁	L ₂	L ₃	L ₄	Travel deviation e _p	Variation V _u				Dynamic Ca	Static Coa
SG0610-133R170C5	110	C5	133	138	145	170	± 0.020	0.018	0.050	~0.005	—	950	1600

Note) Please refer to page A206 for order code of end-journal machining.

SG0801

Shaft dia. $\phi 8$ Lead 1mm

C3&C5

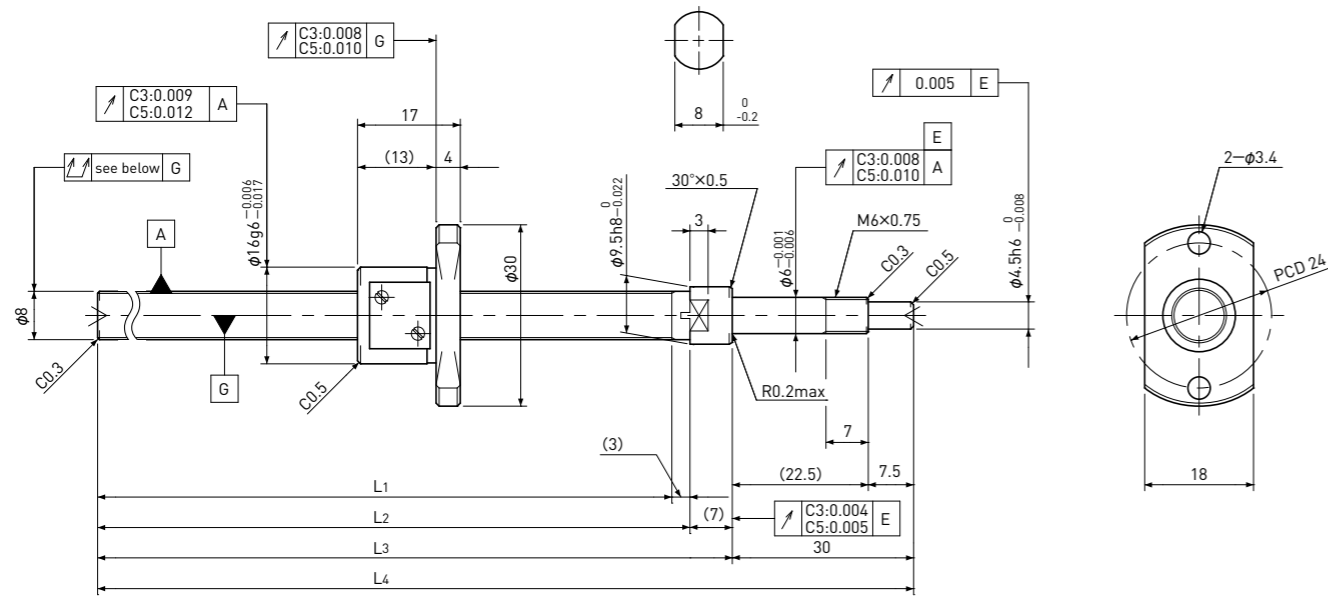

Unit:mm

Ball Screw Specifications	
Ball size	$\phi 0.8$
Number of thread	1
Thread direction	Right
Shaft root dia.	$\phi 7.3$
Number of circuit	3.7×1
Shaft, Nut material	SCM415H
Surface hardness	HRC58~62 (Thread area)
Anti-rust treatment	Anti-rust oil

Supported-side end-journal profile		
A-type	B-type	C-type
$L_5=L_6-40$	$L_5=L_6-49$	$L_5=L_6-49$
L ₅ : Thread length after end-journal machining. L ₆ : Total length after end-journal machining.		
Support-unit Recommendation		Supported-side : MSU-6CS/6GS
		Fixed-side : MSU-6C/6G
D-type : Other than the above.		

Unit:mm

Ball Screw Model	Travel	Grade	Shaft length				Lead accuracy		Total Run-out	Axial play	Preload Torque Nm	Basic Load Rating N	
			L ₁	L ₂	L ₃	L ₄	Travel deviation e _p	Variation V _u				Dynamic Ca	Static Coa
SG0801-100R140C3	80	C3	100	103	110	140	±0.008	0.008	0.035	0 Spacer Ball (1:1)	0.002~ 0.008	490	820
SG0801-130R170C3	110	C3	130	133	140	170	±0.010	0.008	0.035				
SG0801-160R200C3	140	C3	160	163	170	200	±0.010	0.008	0.035				
SG0801-210R250C3	190	C3	210	213	220	250	±0.012	0.008	0.050				
SG0801-100R140C5	80	C5	100	103	110	140	±0.018	0.018	0.050	~0.005	-	780	1650
SG0801-130R170C5	110	C5	130	133	140	170	±0.020	0.018	0.050				
SG0801-160R200C5	140	C5	160	163	170	200	±0.020	0.018	0.050				
SG0801-210R250C5	190	C5	210	213	220	250	±0.023	0.018	0.065				

Note) Please refer to page A206 for order code of end-journal machining.

SG0802

Shaft dia. $\phi 8$ Lead 2mm

C3&C5

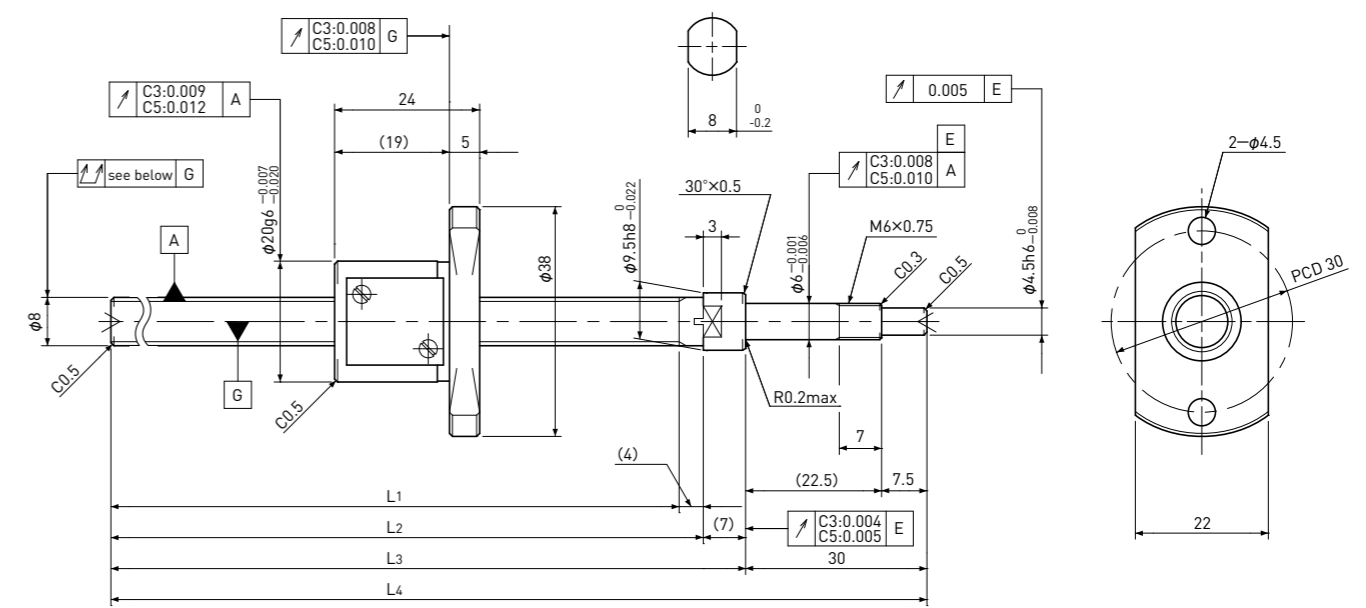

Unit:mm

Ball Screw Specifications	
Ball size	$\phi 1.5875$
Number of thread	1
Thread direction	Right
Shaft root dia.	$\phi 6.6$
Number of circuit	3.7×1
Shaft, Nut material	SCM415H
Surface hardness	HRC58~62 (Thread area)
Anti-rust treatment	Anti-rust oil

Supported-side end-journal profile		
A-type	B-type	C-type
$L_5=L_6-41$	$L_5=L_6-50$	$L_5=L_6-50$
L ₅ : Thread length after end-journal machining. L ₆ : Total length after end-journal machining.		
Support-unit Recommendation		Supported-side : MSU-6CS/6GS
		Fixed-side : MSU-6C/6G
D-type : Other than the above.		

Unit:mm

Ball Screw Model	Travel	Grade	Shaft length				Lead accuracy		Total Run-out	Axial play	Preload Torque Nm	Basic Load Rating N	
			L ₁	L ₂	L ₃	L ₄	Travel deviation e _p	Variation V _u				Dynamic Ca	Static Coa
SG0802-099R140C3	75	C3	99	103	110	140	±0.008	0.008	0.035	0 Spacer Ball (1:1)	0.004~ 0.020	1550	2100
SG0802-129R170C3	105	C3	129	133	140	170	±0.010	0.008	0.035				
SG0802-159R200C3	135	C3	159	163	170	200	±0.010	0.008	0.035				
SG0802-209R250C3	185	C3	209	213	220	250	±0.012	0.008	0.050				
SG0802-099R140C5	75	C5	99	103	110	140	±0.018	0.018	0.050	~0.005	-	2400	4100
SG0802-129R170C5	105	C5	129	133	140	170	±0.020	0.018	0.050				
SG0802-159R200C5	135	C5	159	163	170	200	±0.020	0.018	0.050				
SG0802-209R250C5	185	C5	209	213	220	250	±0.023	0.018	0.065				

Note) Please refer to page A206 for order code of end-journal machining.

SG0802.5 | Shaft dia. $\phi 8$ Lead 2.5mm

C5

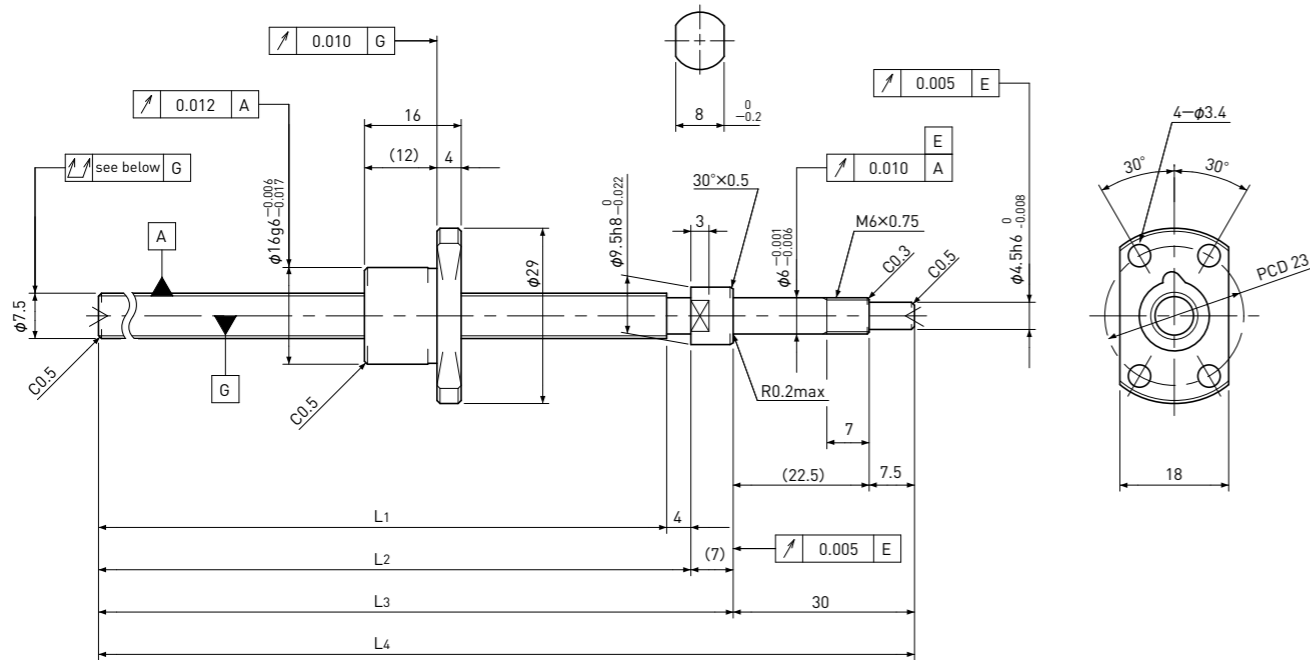

SG0804 | Shaft dia. $\phi 8$ Lead 4mm

C3&C5

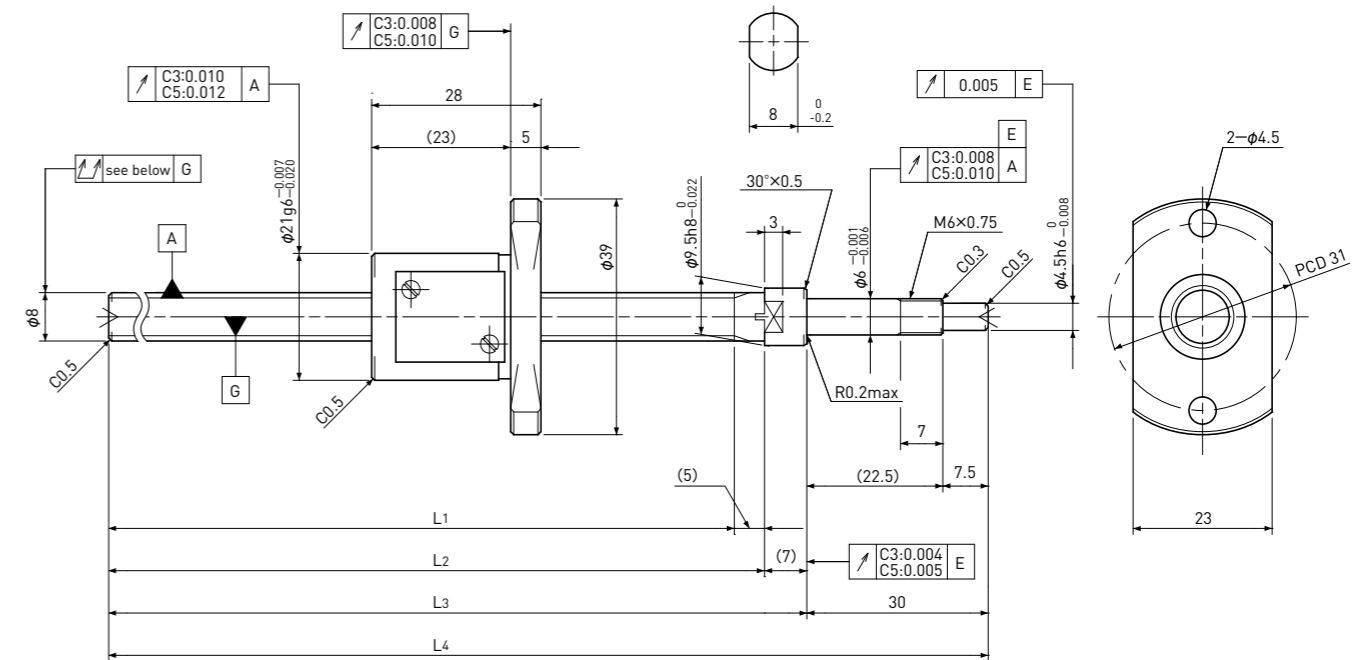

Unit:mm

Ball Screw Specifications	
Ball size	$\phi 1.5875$
Number of thread	1
Thread direction	Right
Shaft root dia.	$\phi 6.3$
Number of circuit	2.7 × 1
Shaft, Nut material	SCM415H
Surface hardness	HRC58~62 (Thread area)
Anti-rust treatment	Anti-rust oil

Supported-side end-journal profile		
A-type	B-type	C-type
$L_5=L_6-41$	$L_5=L_6-50$	$L_5=L_6-50$
L_6	L_6	L_6
L ₅ : Thread length after end-journal machining. L ₆ : Total length after end-journal machining.		
Support-unit Recommendation		Supported-side : MSU-6CS/6GS Fixed-side : MSU-6C/6G
D-type : Other than the above.		

Unit:mm

Ball Screw Model	Travel	Grade	Shaft length				Lead accuracy		Total Run-out	Axial play	Preload Torque Nm	Basic Load Rating N	
			L ₁	L ₂	L ₃	L ₄	Travel deviation e _p	Variation V _u				Dynamic Ca	Static Coa
SG0802.5-129R170C5	110	C5	129	133	140	170	± 0.020	0.018	0.050	~0.005	—	1850	3000
SG0802.5-209R250C5	190	C5	209	213	220	250	± 0.023	0.018	0.065				

Note) Please refer to page A206 for order code of end-journal machining.

Unit:mm

Ball Screw Specifications	
Ball size	$\phi 2.0$
Number of thread	1
Thread direction	Right
Shaft root dia.	$\phi 6.2$
Number of circuit	2.7 × 1
Shaft, Nut material	SCM415H
Surface hardness	HRC58~62 (Thread area)
Anti-rust treatment	Anti-rust oil

Supported-side end-journal profile		
A-type	B-type	C-type
$L_5=L_6-42$	$L_5=L_6-51$	$L_5=L_6-51$
L_6	L_6	L_6
L ₅ : Thread length after end-journal machining. L ₆ : Total length after end-journal machining.		
Support-unit Recommendation		Supported-side : MSU-6CS/6GS Fixed-side : MSU-6C/6G
D-type : Other than the above.		

Unit:mm

Ball Screw Model	Travel	Grade	Shaft length				Lead accuracy		Total Run-out	Axial play	Preload Torque Nm	Basic Load Rating N	
			L ₁	L ₂	L ₃	L ₄	Travel deviation e _p	Variation V _u				Dynamic Ca	Static Coa
SG0804-098R140C3	70	C3	98	103	110	140	± 0.008	0.008	0.035	0 Spacer Ball (1:1)	~0.015	1650	2100
SG0804-208R250C3	180	C3	208	213	220	250	± 0.012	0.008	0.050				
SG0804-098R140C5	70	C5	98	103	110	140	± 0.018	0.018	0.050	~0.005	—	2600	4200
SG0804-208R250C5	180	C5	208	213	220	250	± 0.023	0.018	0.065				

Note) Please refer to page A206 for order code of end-journal machining.

Standard products in stock SG series

SG0805

Shaft dia. $\phi 8$ Lead 5mm

C3&C5

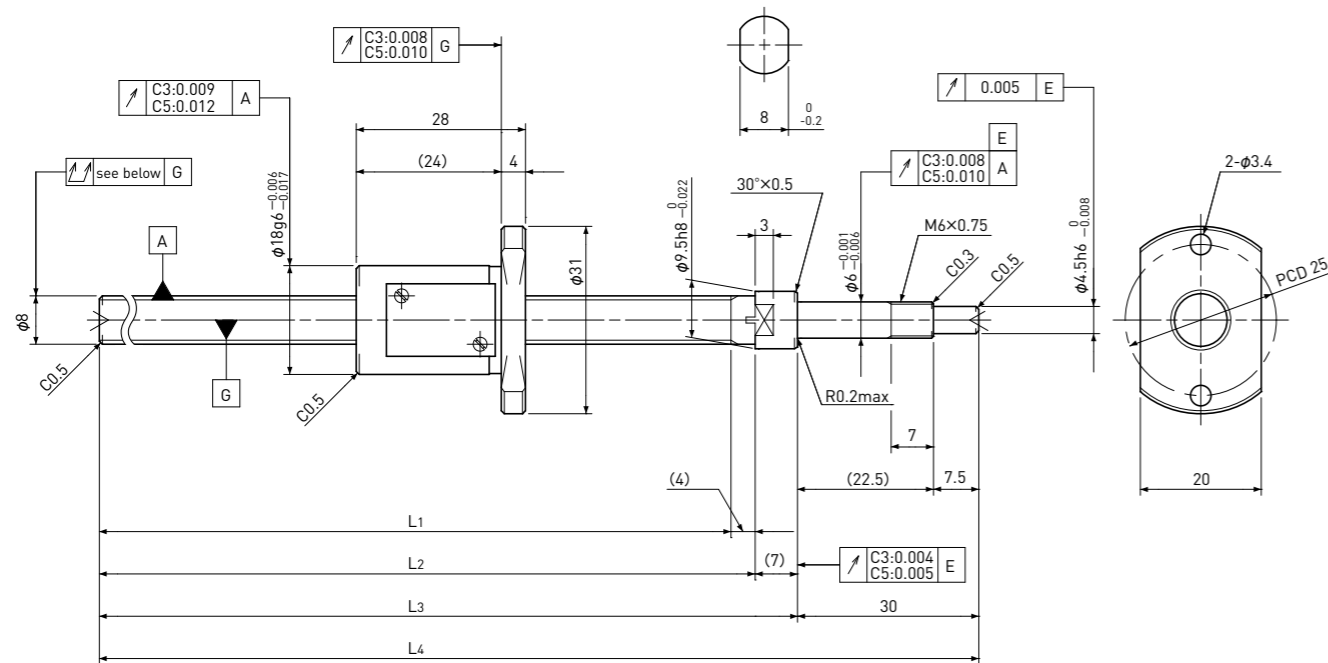

Unit:mm

Ball Screw Specifications	
Ball size	$\phi 1.5875$
Number of thread	1
Thread direction	Right
Shaft root dia.	$\phi 6.6$
Number of circuit	2.7 × 1
Shaft, Nut material	SCM415H
Surface hardness	HRC58~62 (Thread area)
Anti-rust treatment	Anti-rust oil

Supported-side end-journal profile		
A-type	B-type	C-type
L5: Thread length after end-journal machining. L6: Total length after end-journal machining.		
Support-unit Recommendation		Supported-side : MSU-6CS/6GS Fixed-side : MSU-6C/6G
D-type : Other than the above.		

Unit:mm

Ball Screw Model	Travel	Grade	Shaft length				Lead accuracy		Total Run-out	Axial play	Preload Torque Nm	Basic Load Rating N	
			L1	L2	L3	L4	Travel deviation e_p	Variation V_u				Dynamic C_a	Static C_oa
SG0805-099R140C3	70	C3	99	103	110	140	± 0.008	0.008	0.035	0 Spacer Ball (1:1)	~0.015	1150	1500
SG0805-209R250C3	180	C3	209	213	220	250	± 0.012	0.008	0.050				
SG0805-099R140C5	70	C5	99	103	110	140	± 0.018	0.018	0.050	~0.005	—	1850	3000
SG0805-209R250C5	180	C5	209	213	220	250	± 0.023	0.018	0.065				

Note) Please refer to page A206 for order code of end-journal machining.

Standard products in stock SG series

SG0808

Shaft dia. $\phi 8$ Lead 8mm

C5

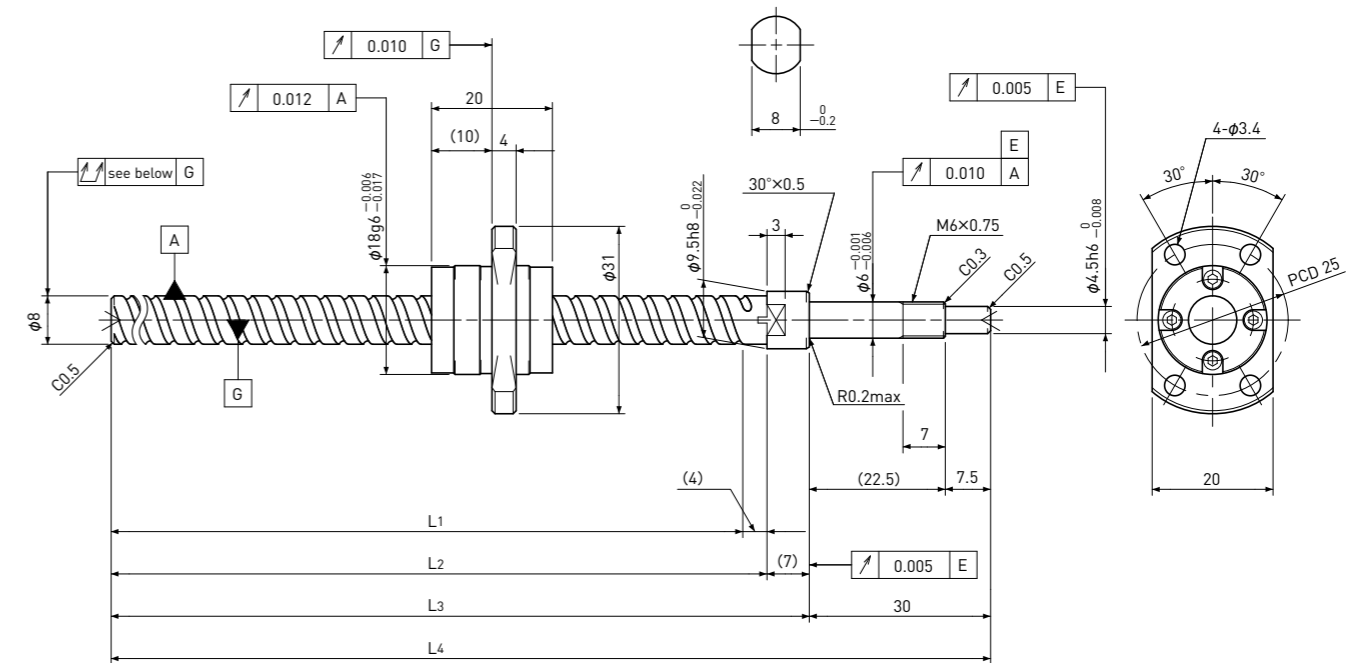

Unit:mm

Ball Screw Specifications	
Ball size	$\phi 1.5875$
Number of thread	2
Thread direction	Right
Shaft root dia.	$\phi 6.7$
Number of circuit	1.6 × 2
Shaft, Nut material	SCM415H
Surface hardness	HRC58~62 (Thread area)
Anti-rust treatment	Anti-rust oil

Supported-side end-journal profile		
A-type	B-type	C-type
L5: Thread length after end-journal machining. L6: Total length after end-journal machining.		
Support-unit Recommendation		Supported-side : MSU-6CS/6GS Fixed-side : MSU-6C/6G
D-type : Other than the above.		

Unit:mm

Ball Screw Model	Travel	Grade	Shaft length				Lead accuracy		Total Run-out	Axial play	Preload Torque Nm	Basic Load Rating N	
			L1	L2	L3	L4	Travel deviation e_p	Variation V_u				Dynamic C_a	Static C_oa
SG0808-099R140C5	75	C5	99	103	110	140	± 0.018	0.018	0.050	~0.005	—	2200	3800
SG0808-209R250C5	185	C5	209	213	220	250	± 0.023	0.018	0.065				

Note) Please refer to page A206 for order code of end-journal machining.

SG0812

Shaft dia. $\phi 8$ Lead 12mm

C5

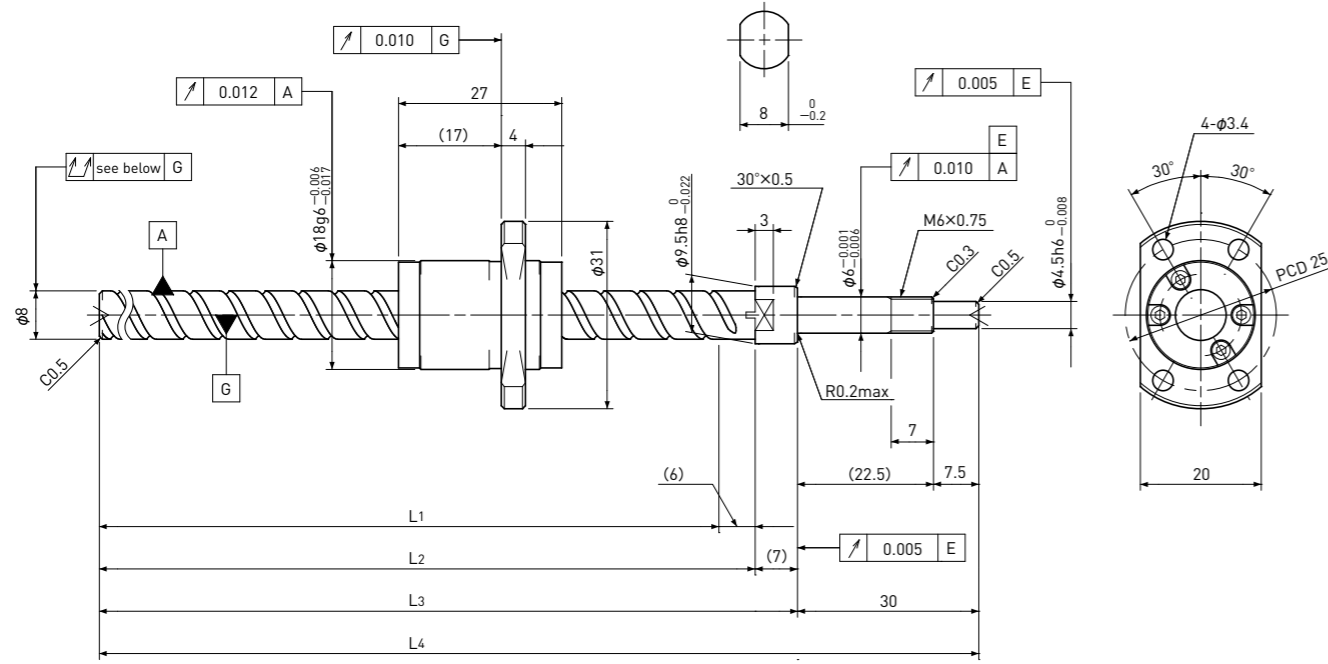

Ball Screw Specifications	
Ball size	$\phi 1.5875$
Number of thread	2
Thread direction	Right
Shaft root dia.	$\phi 6.7$
Number of circuit	1.6 × 2
Shaft, Nut material	SCM415H
Surface hardness	HRC58~62 (Thread area)
Anti-rust treatment	Anti-rust oil

Supported-side end-journal profile			
	A-type	B-type	C-type
Diagram			
Dimensions	$L_5=L_6-43$	$L_5=L_6-52$	$L_5=L_6-52$
Notes	L ₅ : Thread length after end-journal machining. L ₆ : Total length after end-journal machining.		
Support-unit Recommendation	Supported-side : MSU-6CS/6GS Fixed-side : MSU-6C/6G		
D-type : Other than the above.			

Ball Screw Model	Travel	Grade	Shaft length				Lead accuracy		Total Run-out	Axial play	Preload Torque Nm	Basic Load Rating N	
			L ₁	L ₂	L ₃	L ₄	Travel deviation e _p	Variation V _u				Dynamic Ca	Static Coa
SG0812-097R140C5	70	C5	97	103	110	140	± 0.018	0.018	0.050	~0.005	—	2200	4000
SG0812-207R250C5	180	C5	207	213	220	250	± 0.023	0.018	0.065				

Note) Please refer to page A206 for order code of end-journal machining.

SG1001

Shaft dia. $\phi 10$ Lead 1mm

C3&C5

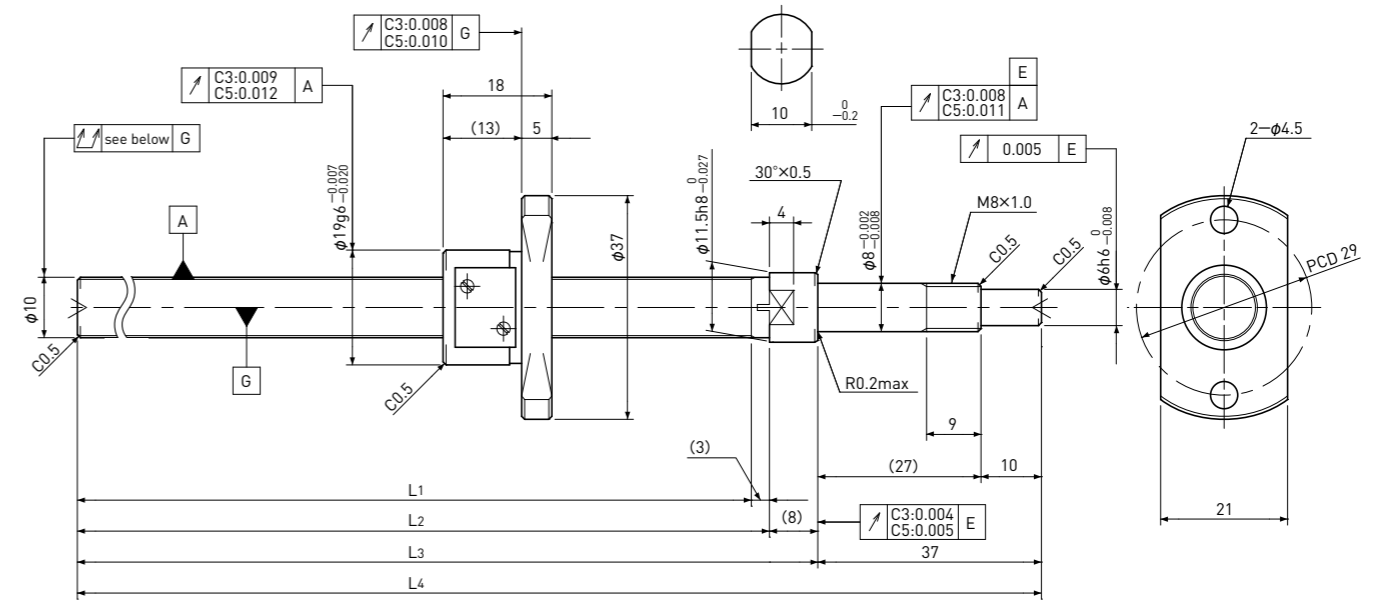

Ball Screw Specifications	
Ball size	$\phi 0.8$
Number of thread	1
Thread direction	Right
Shaft root dia.	$\phi 9.3$
Number of circuit	3.7 × 1
Shaft, Nut material	SCM415H
Surface hardness	HRC58~62 (Thread area)
Anti-rust treatment	Anti-rust oil

Supported-side end-journal profile			
	A-type	B-type	C-type
Diagram			
Dimensions	$L_5=L_6-48$	$L_5=L_6-57$	$L_5=L_6-57$
Notes	L ₅ : Thread length after end-journal machining. L ₆ : Total length after end-journal machining.		
Support-unit Recommendation	Supported-side : MSU-8CS/8GS Fixed-side : MSU-8C/8G		
D-type : Other than the above.			

Ball Screw Model	Travel	Grade	Shaft length				Lead accuracy		Total Run-out	Axial play	Preload Torque Nm	Basic Load Rating N	
			L ₁	L ₂	L ₃	L ₄	Travel deviation e _p	Variation V _u				Dynamic Ca	Static Coa
SG1001-112R160C3	90	C3	112	115	123	160	± 0.010	0.008	0.035	0 Spacer Ball (1:1)	~0.020	530	1000
SG1001-162R210C3	140	C3	162	165	173	210	± 0.010	0.008	0.040				
SG1001-212R260C3	190	C3	212	215	223	260	± 0.012	0.008	0.040				
SG1001-262R310C3	240	C3	262	265	273	310	± 0.012	0.008	0.040				
SG1001-112R160C5	90	C5	112	115	123	160	± 0.020	0.018	0.040	~0.005	—	840	2000
SG1001-162R210C5	140	C5	162	165	173	210	± 0.020	0.018	0.055				
SG1001-212R260C5	190	C5	212	215	223	260	± 0.023	0.018	0.055				
SG1001-262R310C5	240	C5	262	265	273	310	± 0.023	0.018	0.055				

Note) Please refer to page A206 for order code of end-journal machining.

Standard products in stock SG series

SG1002 | Shaft dia. $\phi 10$ Lead 2mm | **C3&C5**

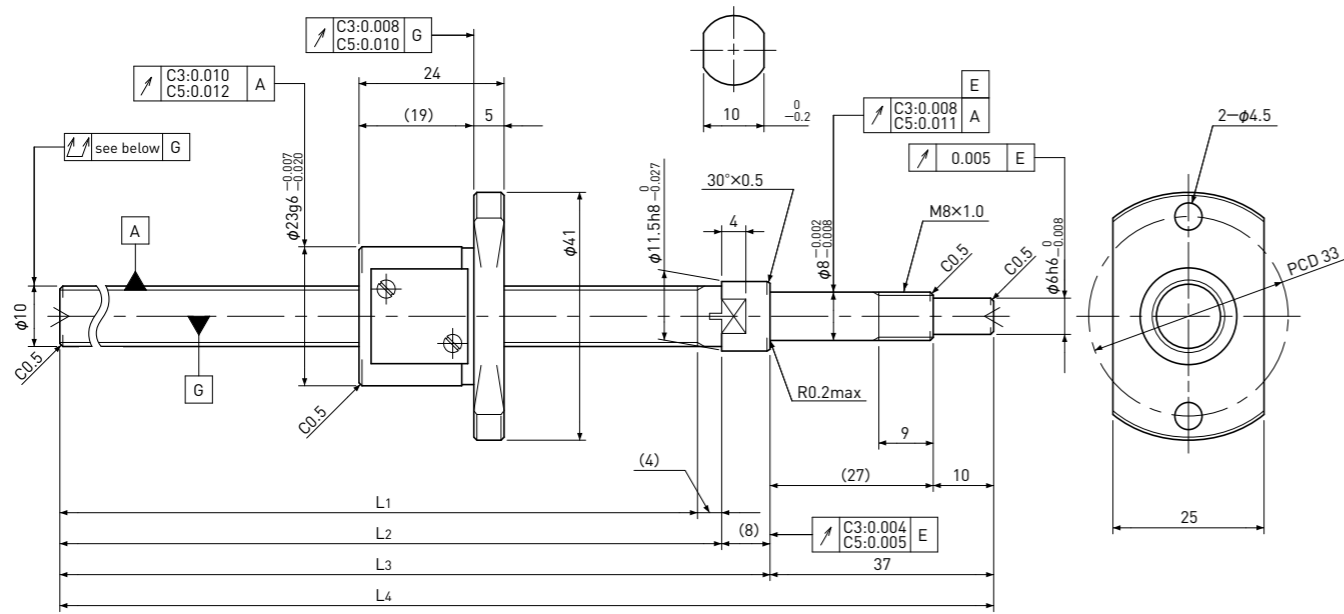

Unit:mm

Ball Screw Specifications	
Ball size	$\phi 1.5875$
Number of thread	1
Thread direction	Right
Shaft root dia.	$\phi 8.6$
Number of circuit	3.7×1
Shaft, Nut material	SCM415H
Surface hardness	HRC58~62 (Thread area)
Anti-rust treatment	Anti-rust oil

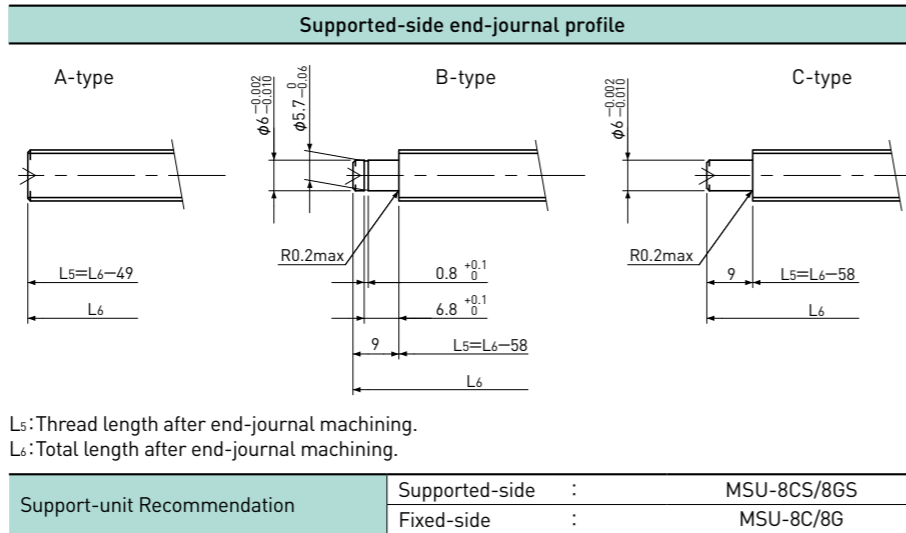

Unit:mm

Ball Screw Model	Travel	Grade	Shaft length				Lead accuracy		Total Run-out	Axial play	Preload Torque Nm	Basic Load Rating N	
			L ₁	L ₂	L ₃	L ₄	Travel deviation e _p	Variation V _u				Dynamic Ca	Static Coa
SG1002-111R160C3	85	C3	111	115	123	160	±0.010	0.008	0.035	0 Spacer Ball (1:1)	0.006~ 0.030	1750	2700
SG1002-161R210C3	135	C3	161	165	173	210	±0.010	0.008	0.040				
SG1002-211R260C3	185	C3	211	215	223	260	±0.012	0.008	0.040				
SG1002-261R310C3	235	C3	261	265	273	310	±0.012	0.008	0.040				
SG1002-111R160C5	85	C5	111	115	123	160	±0.020	0.018	0.040	~0.005	-	2700	5300
SG1002-161R210C5	135	C5	161	165	173	210	±0.020	0.018	0.055				
SG1002-211R260C5	185	C5	211	215	223	260	±0.023	0.018	0.055				
SG1002-261R310C5	235	C5	261	265	273	310	±0.023	0.018	0.055				

Note)Please refer to page A206 for order code of end-journal machining.

Standard products in stock SG series

SG1004 | Shaft dia. $\phi 10$ Lead 4mm | **C3&C5**

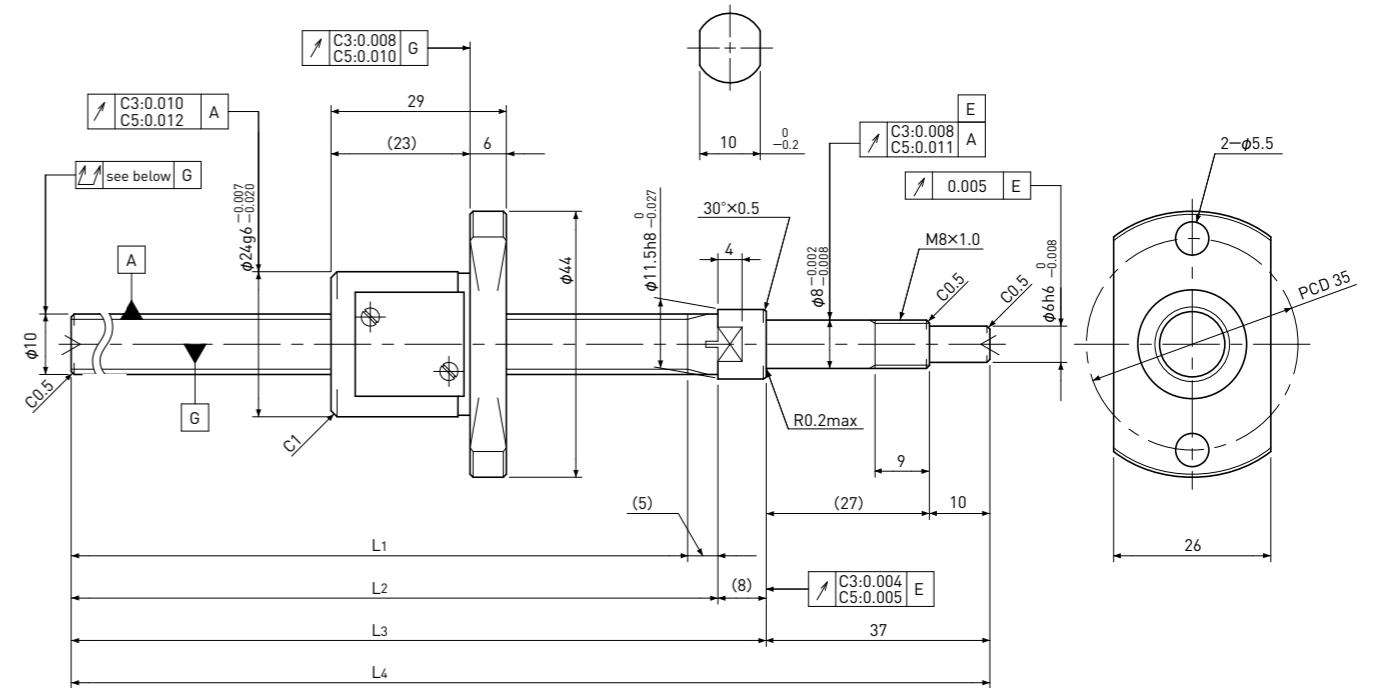

Unit:mm

Ball Screw Specifications	
Ball size	$\phi 2.0$
Number of thread	1
Thread direction	Right
Shaft root dia.	$\phi 8.2$
Number of circuit	2.7×1
Shaft, Nut material	SCM415H
Surface hardness	HRC58~62 (Thread area)
Anti-rust treatment	Anti-rust oil

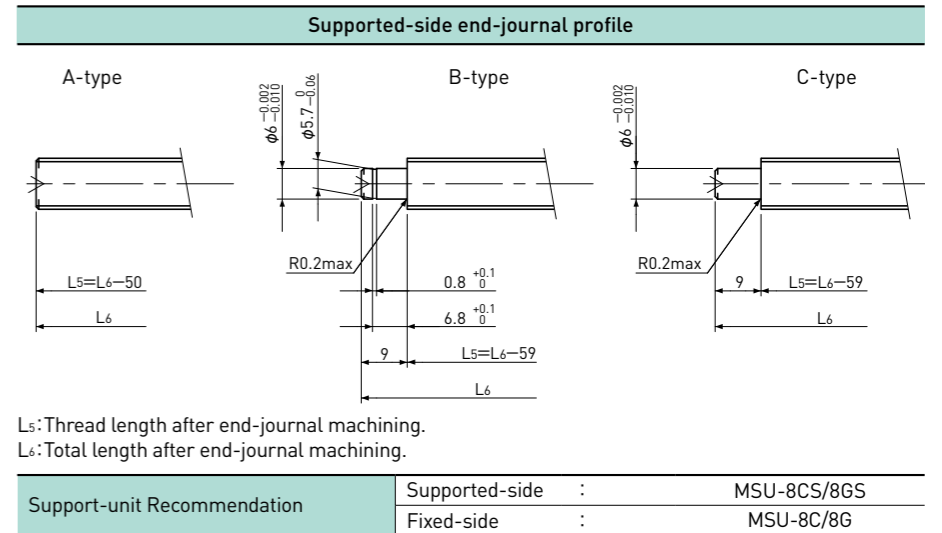

Unit:mm

Ball Screw Model	Travel	Grade	Shaft length				Lead accuracy		Total Run-out	Axial play	Preload Torque Nm	Basic Load Rating N	
			L ₁	L ₂	L ₃	L ₄	Travel deviation e _p	Variation V _u				Dynamic Ca	Static Coa
SG1004-110R160C3	80	C3	110	115	123	160	±0.010	0.008	0.035	0 Spacer Ball (1:1)	0.005~ 0.040	1800	2600
SG1004-260R310C3	230	C3	260	265	273	310	±0.012	0.008	0.040				
SG1004-110R160C5	80	C5	110	115	123	160	±0.020	0.018	0.040	~0.005	-	3000	5200
SG1004-260R310C5	230	C5	260	265	273	310	±0.023	0.018	0.055				

Note)Please refer to page A206 for order code of end-journal machining.

Standard products in stock SG series

SG1005 | Shaft dia. $\phi 10$ Lead 5mm | **C3&C5**

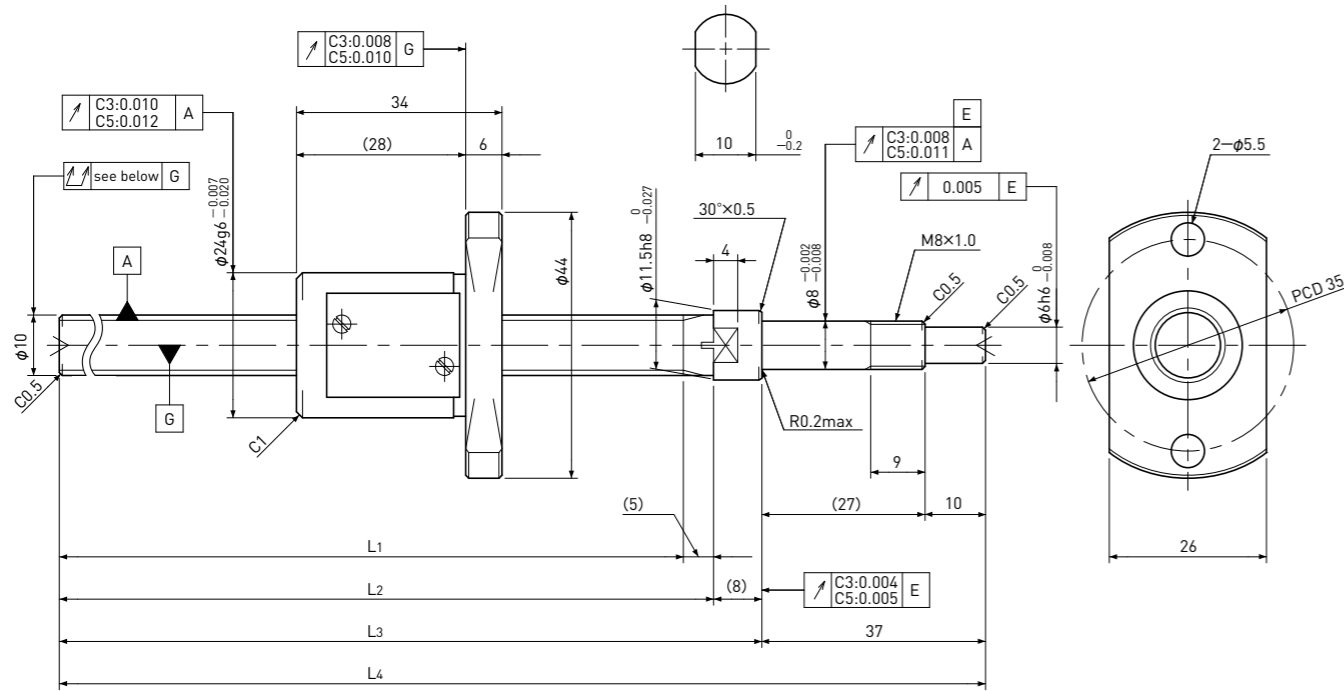

Unit:mm

Ball Screw Specifications	
Ball size	$\phi 2.0$
Number of thread	1
Thread direction	Right
Shaft root dia.	$\phi 8.2$
Number of circuit	2.7 × 1
Shaft, Nut material	SCM415H
Surface hardness	HRC58~62 (Thread area)
Anti-rust treatment	Anti-rust oil

Supported-side end-journal profile		
A-type	B-type	C-type
$L_5=L_6-50$	$L_5=L_6-59$	$L_5=L_6-59$
L ₅ : Thread length after end-journal machining. L ₆ : Total length after end-journal machining.		
Support-unit Recommendation		Supported-side : MSU-8CS/8GS
		Fixed-side : MSU-8C/8G
D-type : Other than the above.		

Unit:mm

Ball Screw Model	Travel	Grade	Shaft length				Lead accuracy		Total Run-out	Axial play	Preload Torque Nm	Basic Load Rating N	
			L ₁	L ₂	L ₃	L ₄	Travel deviation e _p	Variation V _u				Dynamic Ca	Static Coa
SG1005-110R160C3	75	C3	110	115	123	160	± 0.010	0.008	0.035	0 Spacer Ball (1:1)	0.005~0.040	1800	2600
SG1005-260R310C3	225	C3	260	265	273	310	± 0.012	0.008	0.040				
SG1005-110R160C5	75	C5	110	115	123	160	± 0.020	0.018	0.040	~0.005	—	3000	5200
SG1005-260R310C5	225	C5	260	265	273	310	± 0.023	0.018	0.055				

Note) Please refer to page A206 for order code of end-journal machining.

Standard products in stock SG series

SG1010 | Shaft dia. $\phi 10$ Lead 10mm | **C5**

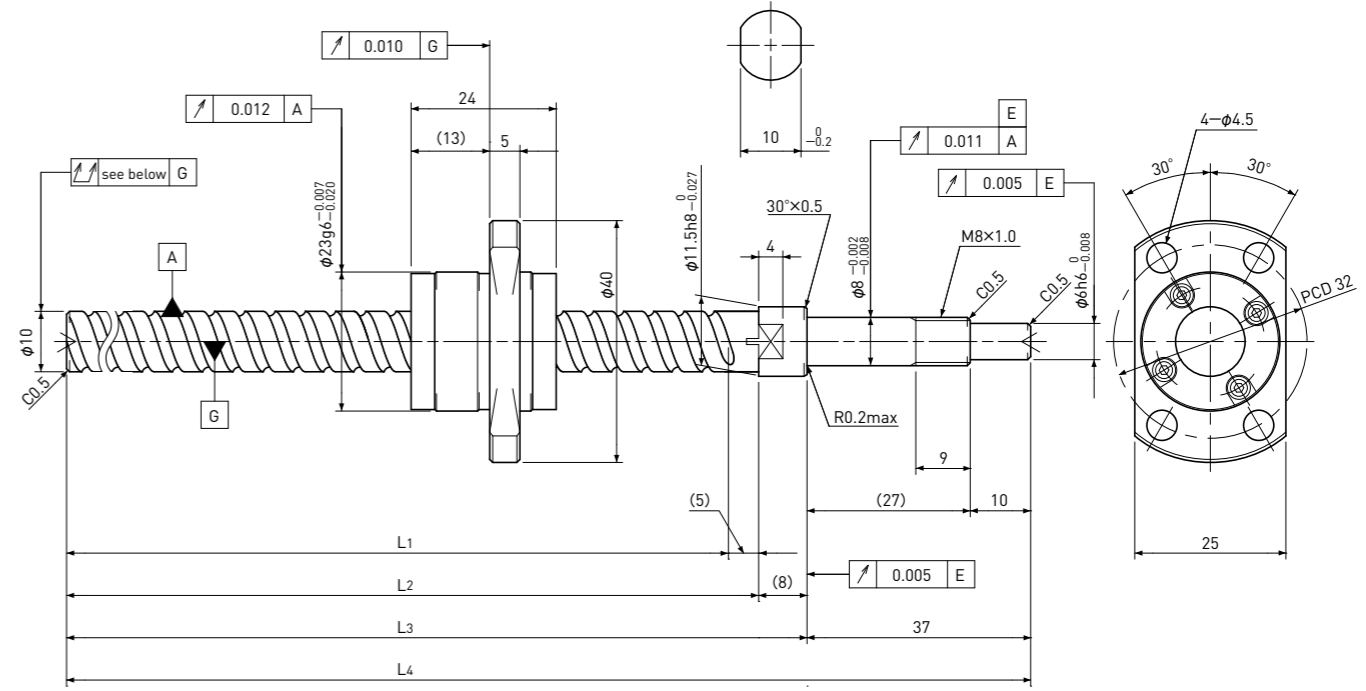

Unit:mm

Ball Screw Specifications	
Ball size	$\phi 2.0$
Number of thread	2
Thread direction	Right
Shaft root dia.	$\phi 8.4$
Number of circuit	1.6 × 2
Shaft, Nut material	SCM415H
Surface hardness	HRC58~62 (Thread area)
Anti-rust treatment	Anti-rust oil

Supported-side end-journal profile		
A-type	B-type	C-type
$L_5=L_6-50$	$L_5=L_6-59$	$L_5=L_6-59$
L ₅ : Thread length after end-journal machining. L ₆ : Total length after end-journal machining.		
Support-unit Recommendation		Supported-side : MSU-8CS/8GS
		Fixed-side : MSU-8C/8G
D-type : Other than the above.		

Unit:mm

Ball Screw Model	Travel	Grade	Shaft length				Lead accuracy		Total Run-out	Axial play	Preload Torque Nm	Basic Load Rating N	
			L ₁	L ₂	L ₃	L ₄	Travel deviation e _p	Variation V _u				Dynamic Ca	Static Coa
SG1010-110R160C5	85	C5	110	115	123	160	± 0.020	0.018	0.040	~0.005	—	3300	5900
SG1010-260R310C5	235	C5	260	265	273	310	± 0.023	0.018	0.055				

Note) Please refer to page A206 for order code of end-journal machining.

SG1015

Shaft dia. $\phi 10$ Lead 15mm

C5

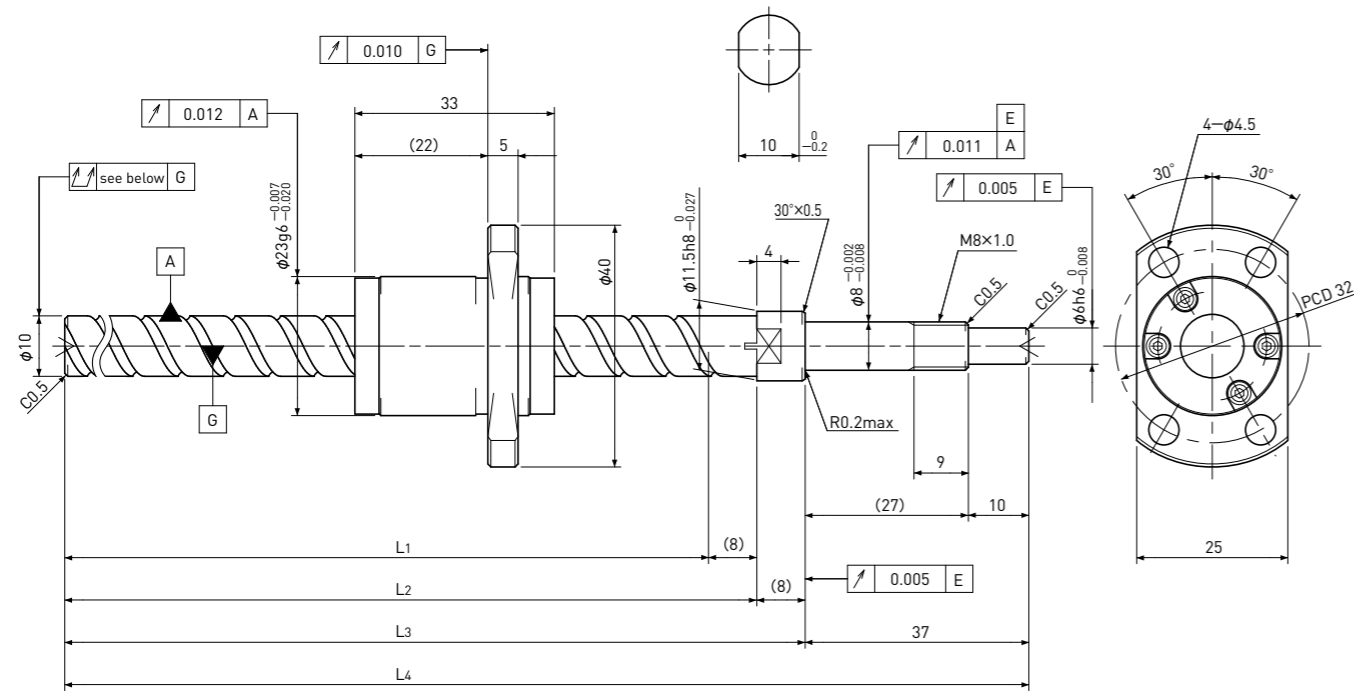

Unit:mm

Ball Screw Specifications	
Ball size	$\phi 2.0$
Number of thread	2
Thread direction	Right
Shaft root dia.	$\phi 8.4$
Number of circuit	1.6 x 2
Shaft, Nut material	SCM415H
Surface hardness	HRC58~62 (Thread area)
Anti-rust treatment	Anti-rust oil

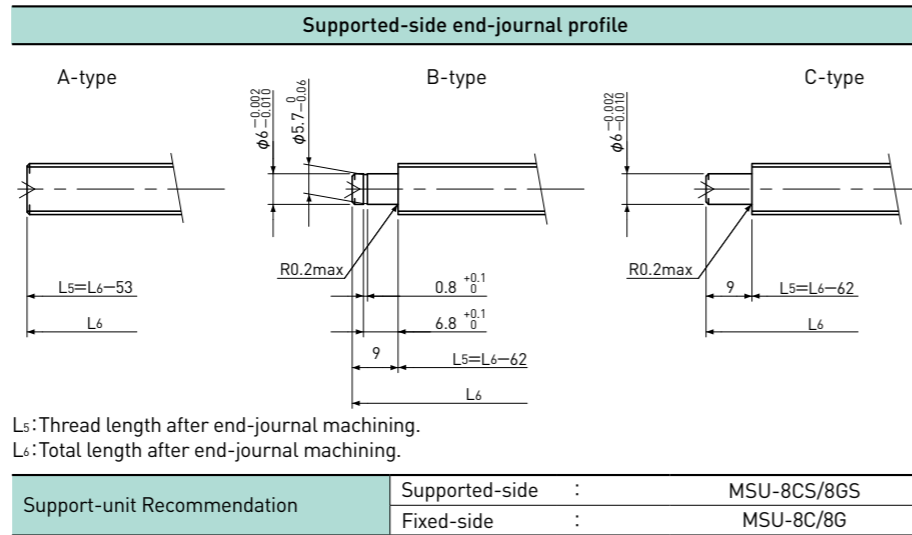

Unit:mm

Ball Screw Model	Travel	Grade	Shaft length				Lead accuracy		Total Run-out	Axial play	Preload Torque Nm	Basic Load Rating N	
			L1	L2	L3	L4	Travel deviation e_p	Variation V_u				Dynamic C_a	Static C_oa
SG1015-107R160C5	70	C5	107	115	123	160	± 0.020	0.018	0.040	~0.005	—	3300	6400
SG1015-257R310C5	220	C5	257	265	273	310	± 0.023	0.018	0.055				

Note) Please refer to page A206 for order code of end-journal machining.

SG1202

Shaft dia. $\phi 12$ Lead 2mm

C3&C5

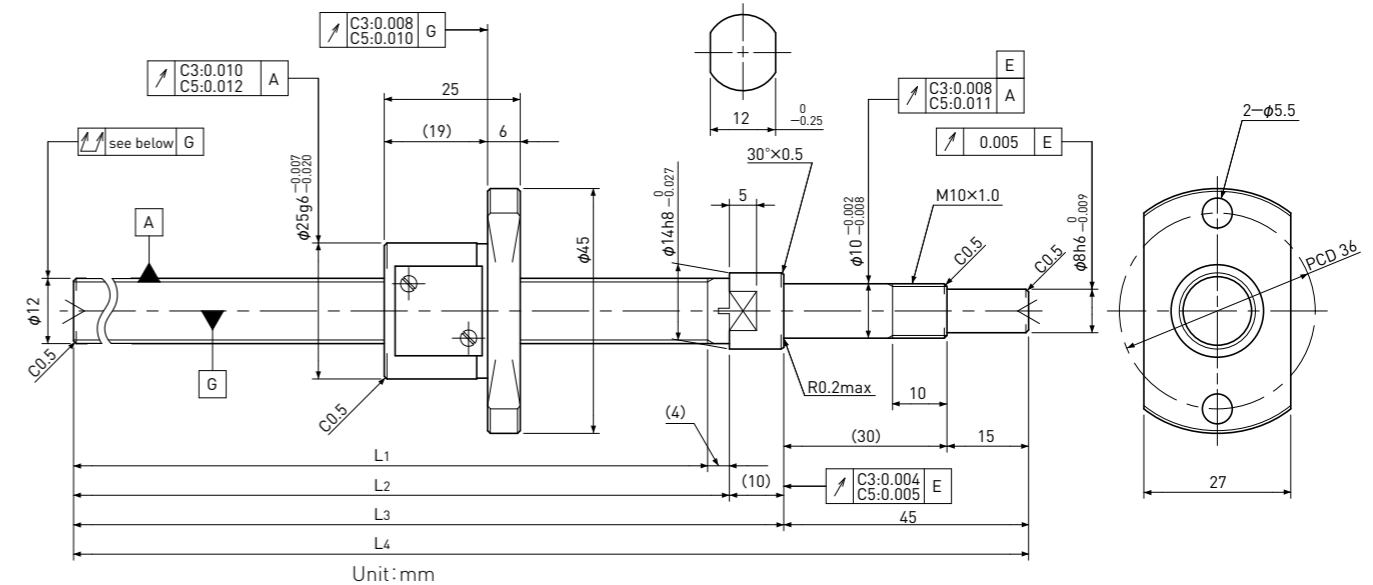

Unit:mm

Ball Screw Specifications	
Ball size	$\phi 1.5875$
Number of thread	1
Thread direction	Right
Shaft root dia.	$\phi 10.6$
Number of circuit	3.7 x 1
Shaft, Nut material	SCM415H
Surface hardness	HRC58~62 (Thread area)
Anti-rust treatment	Anti-rust oil

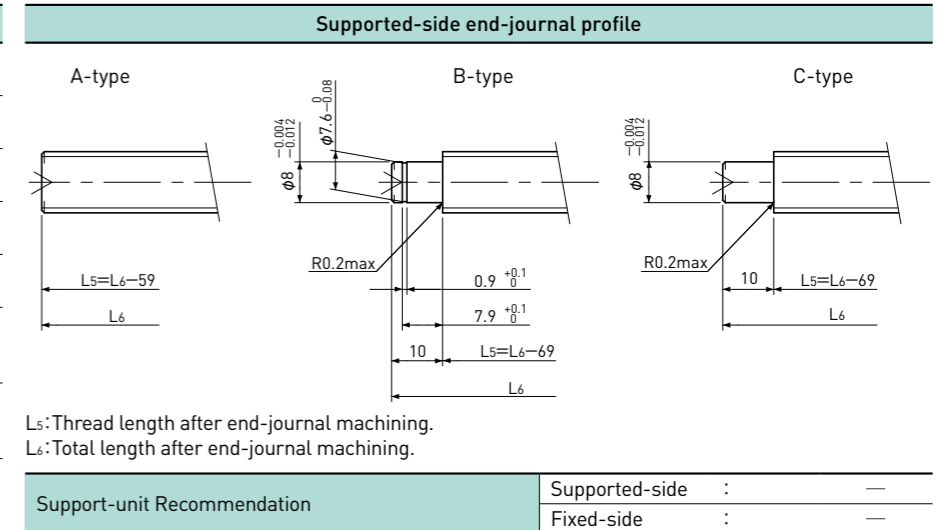

Unit:mm

Ball Screw Model	Travel	Grade	Shaft length				Lead accuracy		Total Run-out	Axial play	Preload Torque Nm	Basic Load Rating N	
			L1	L2	L3	L4	Travel deviation e_p	Variation V_u				Dynamic C_a	Static C_oa
SG1202-141R200C3	115	C3	141	145	155	200	± 0.010	0.008	0.035	0 Spacer Ball (1:1)	0.008~0.040	1900	3200
SG1202-191R250C3	165	C3	191	195	205	250	± 0.010	0.008	0.040				
SG1202-241R300C3	215	C3	241	245	255	300	± 0.012	0.008	0.040				
SG1202-291R350C3	265	C3	291	295	305	350	± 0.012	0.008	0.050				
SG1202-341R400C3	315	C3	341	345	355	400	± 0.013	0.010	0.050				
SG1202-141R200C5	115	C5	141	145	155	200	± 0.020	0.018	0.040	~0.005	—	3000	6400
SG1202-191R250C5	165	C5	191	195	205	250	± 0.020	0.018	0.055				
SG1202-241R300C5	215	C5	241	245	255	300	± 0.023	0.018	0.055				
SG1202-291R350C5	265	C5	291	295	305	350	± 0.023	0.018	0.065				
SG1202-341R400C5	315	C5	341	345	355	400	± 0.025	0.020	0.065				

Note) Please refer to page A206 for order code of end-journal machining.

SG1210

Shaft dia. $\phi 12$ Lead 10mm

C5

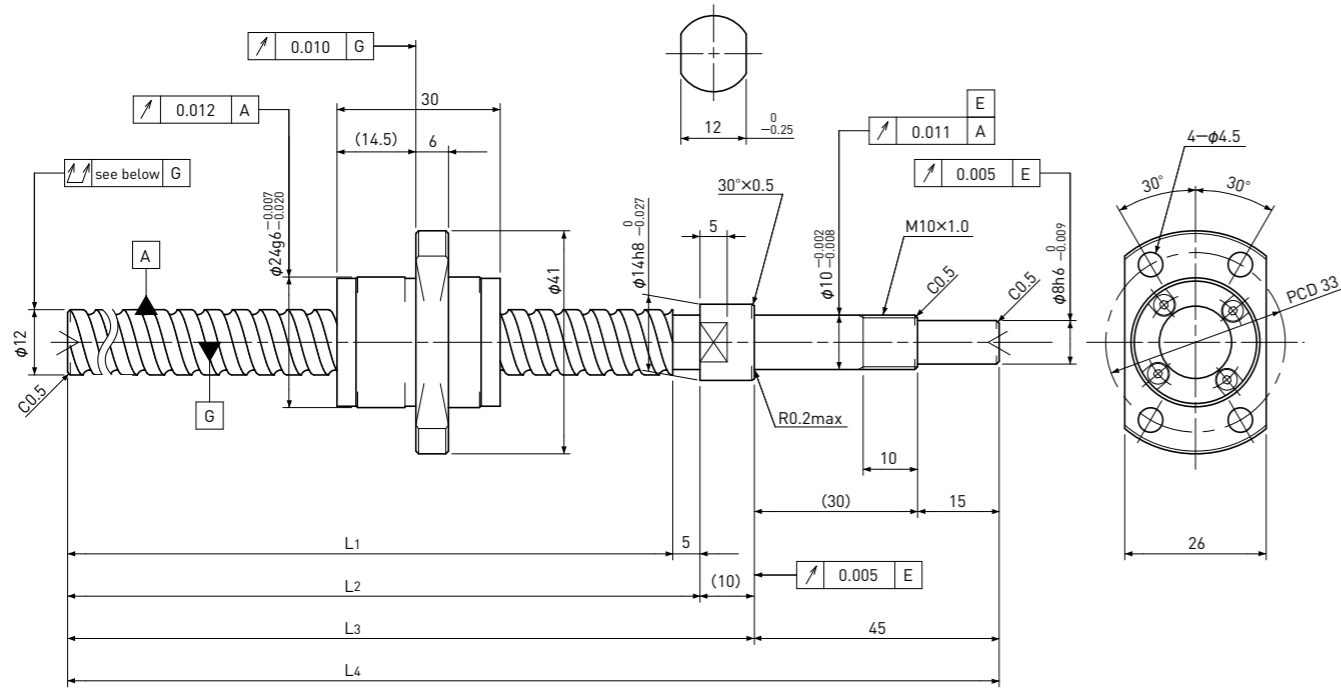

Unit:mm

Ball Screw Specifications	
Ball size	$\phi 2.381$
Number of thread	2
Thread direction	Right
Shaft root dia.	$\phi 10.2$
Number of circuit	1.7×2
Shaft, Nut material	SCM415H
Surface hardness	HRC58~62 (Thread area)
Anti-rust treatment	Anti-rust oil

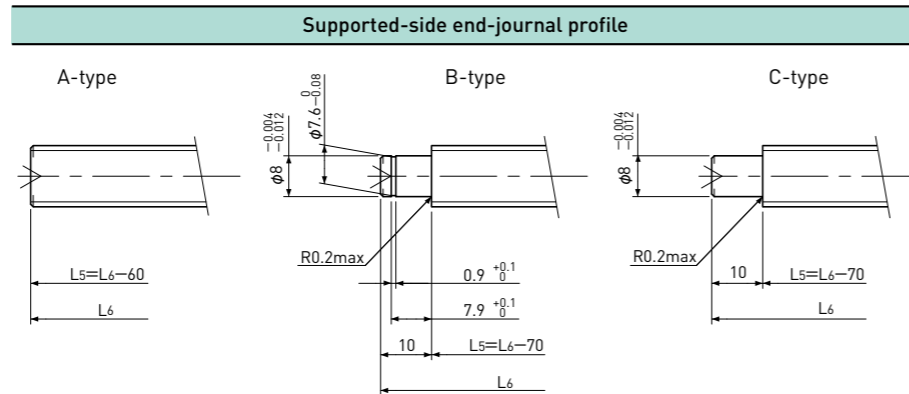

L5: Thread length after end-journal machining.
L6: Total length after end-journal machining.

Support-unit Recommendation	Supported-side	Fixed-side
	—	—

D-type : Other than the above.

Unit:mm

Ball Screw Model	Travel	Grade	Shaft length				Lead accuracy		Total Run-out	Axial play	Preload Torque Nm	Basic Load Rating N	
			L1	L2	L3	L4	Travel deviation e_p	Variation V_u				Dynamic C_a	Static C_oa
SG1210-240R300C5	210	C5	240	245	255	300	± 0.023	0.018	0.055	~0.005	—	5100	9800
SG1210-340R400C5	310	C5	340	345	355	400	± 0.025	0.020	0.065				

Note) Please refer to page A206 for order code of end-journal machining.

SG1402

Shaft dia. $\phi 14$ Lead 2mm

C3&C5

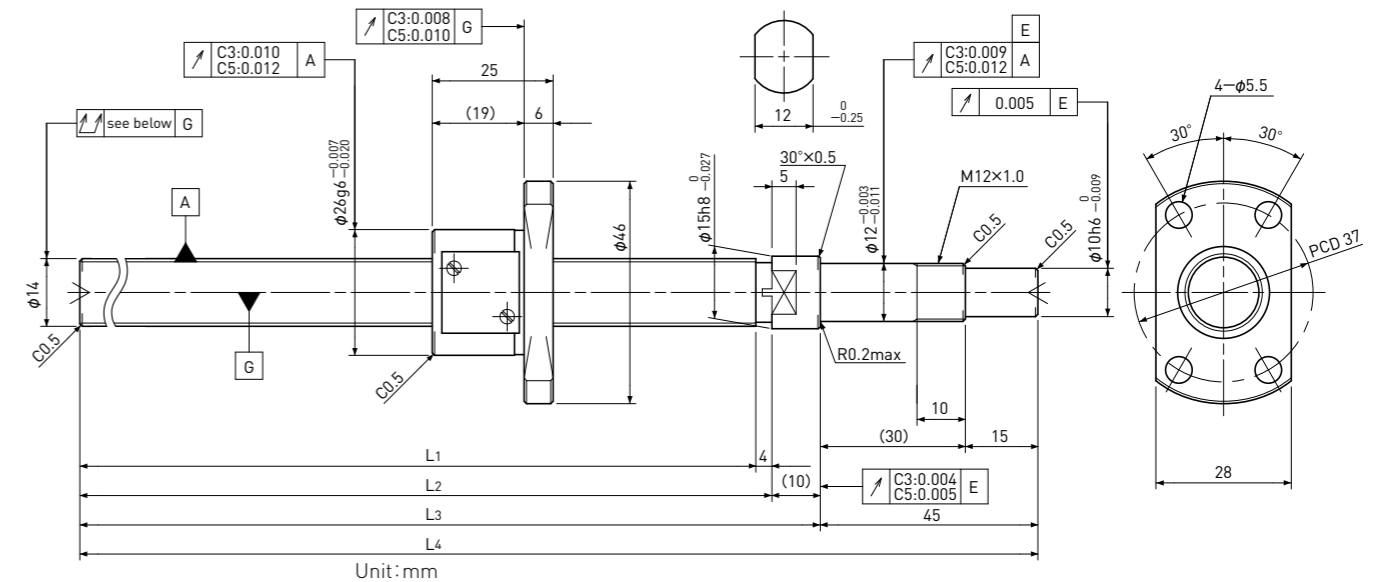

Unit:mm

Ball Screw Specifications	
Ball size	$\phi 1.5875$
Number of thread	1
Thread direction	Right
Shaft root dia.	$\phi 12.6$
Number of circuit	3.7×1
Shaft, Nut material	SCM415H
Surface hardness	HRC58~62 (Thread area)
Anti-rust treatment	Anti-rust oil

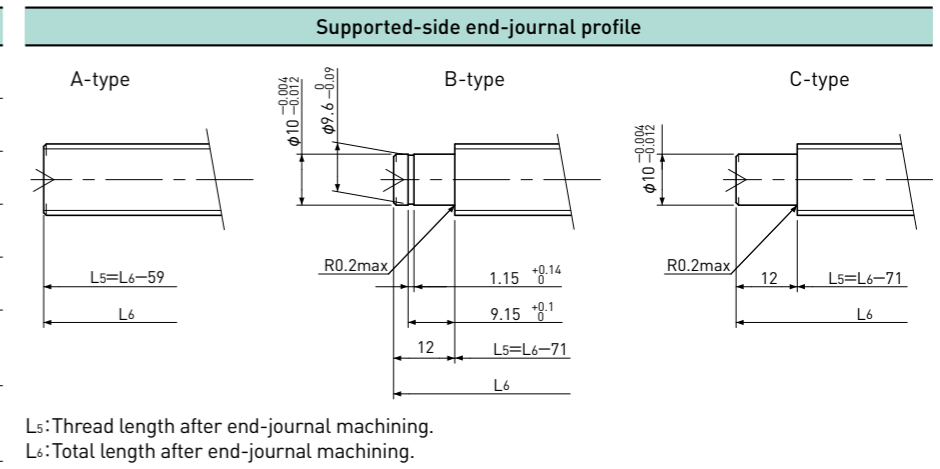

L5: Thread length after end-journal machining.
L6: Total length after end-journal machining.

Support-unit Recommendation	Supported-side	Fixed-side
	—	—

D-type : Other than the above.

Unit:mm

Ball Screw Model	Travel	Grade	Shaft length				Lead accuracy		Total Run-out	Axial play	Preload Torque Nm	Basic Load Rating N	
			L1	L2	L3	L4	Travel deviation e_p	Variation V_u				Dynamic C_a	Static C_oa
SG1402-141R200C3	115	C3	141	145	155	200	± 0.010	0.008	0.025	0 Spacer Ball (1:1)	0.010~0.050	2000	3800
SG1402-191R250C3	165	C3	191	195	205	250	± 0.010	0.008	0.030				
SG1402-241R300C3	215	C3	241	245	255	300	± 0.012	0.008	0.030				
SG1402-291R350C3	265	C3	291	295	305	350	± 0.012	0.008	0.040				
SG1402-391R450C3	365	C3	391	395	405	450	± 0.013	0.010	0.050				
SG1402-141R200C5	115	C5	141	145	155	200	± 0.020	0.018	0.040	~0.005	—	3200	7500
SG1402-191R250C5	165	C5	191	195	205	250	± 0.020	0.018	0.045				
SG1402-241R300C5	215	C5	241	245	255	300	± 0.023	0.018	0.045				
SG1402-291R350C5	265	C5	291	295	305	350	± 0.023	0.018	0.055				
SG1402-391R450C5	365	C5	391	395	405	450	± 0.025	0.020	0.060				

Note) Please refer to page A206 for order code of end-journal machining.

SG1404

Shaft dia. $\phi 14$ Lead 4mm

C3&C5

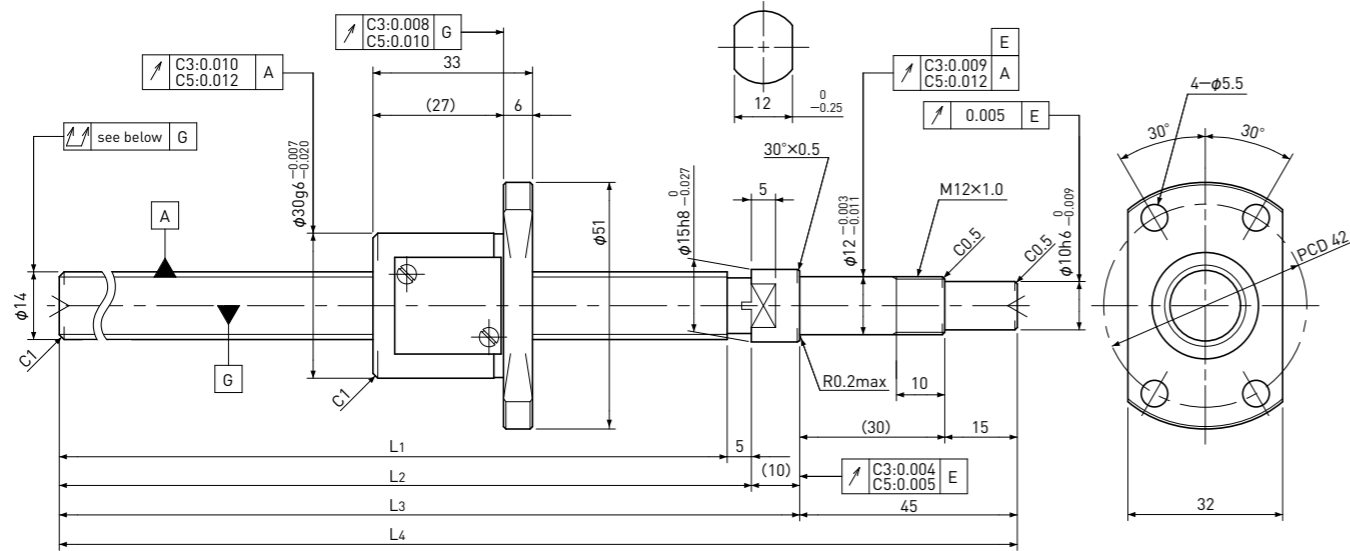

Unit:mm

Ball Screw Specifications	
Ball size	$\phi 2.381$
Number of thread	1
Thread direction	Right
Shaft root dia.	$\phi 11.8$
Number of circuit	3.7×1
Shaft, Nut material	SCM415H
Surface hardness	HRC58~62 (Thread area)
Anti-rust treatment	Anti-rust oil

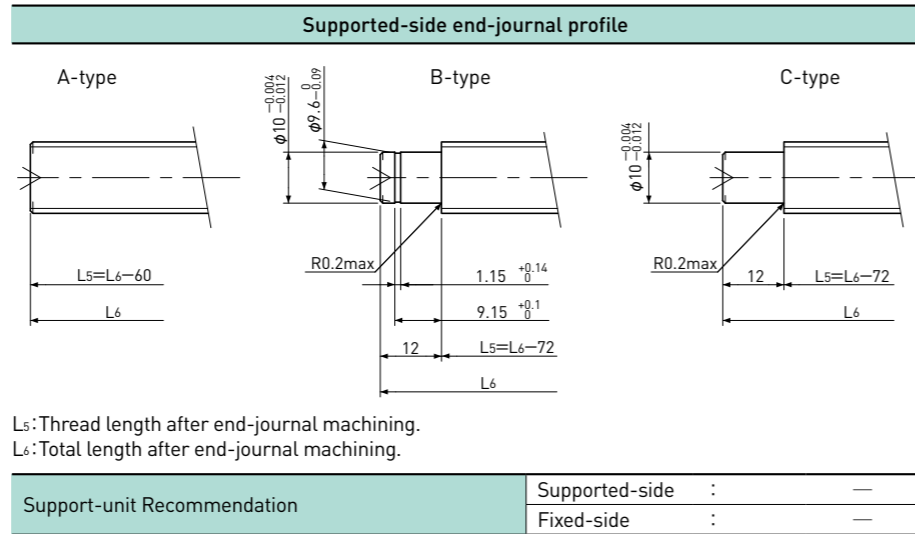

Ball Screw Model	Travel	Grade	Shaft length				Lead accuracy		Total Run-out	Axial play	Preload Torque Nm	Basic Load Rating N	
			L ₁	L ₂	L ₃	L ₄	Travel deviation e _p	Variation V ₀				Dynamic Ca	Static Coa
SG1404-190R250C3	155	C3	190	195	205	250	±0.010	0.008	0.030	0 Spacer Ball (1:1)	0.020~0.070	3600	5800
SG1404-240R300C3	205	C3	240	245	255	300	±0.012	0.008	0.030				
SG1404-290R350C3	255	C3	290	295	305	350	±0.012	0.008	0.040				
SG1404-390R450C3	355	C3	390	395	405	450	±0.013	0.010	0.050				
SG1404-490R550C3	455	C3	490	495	505	550	±0.015	0.010	0.055				
SG1404-190R250C5	155	C5	190	195	205	250	±0.020	0.018	0.045	~0.005	—	5700	11600
SG1404-240R300C5	205	C5	240	245	255	300	±0.023	0.018	0.045				
SG1404-290R350C5	255	C5	290	295	305	350	±0.023	0.018	0.055				
SG1404-390R450C5	355	C5	390	395	405	450	±0.025	0.020	0.060				
SG1404-490R550C5	455	C5	490	495	505	550	±0.027	0.020	0.075				

Note) Please refer to page A206 for order code of end-journal machining.

SG1505

Shaft dia. $\phi 15$ Lead 5mm

C5

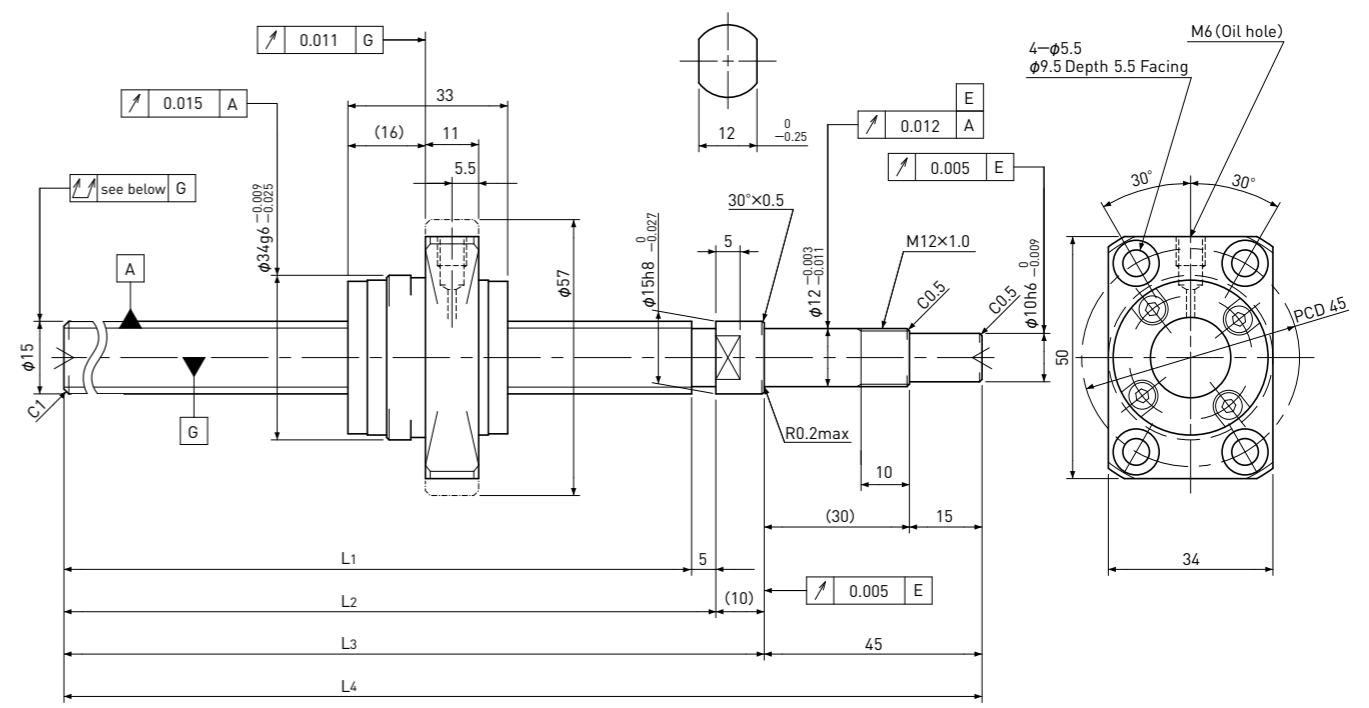

Unit:mm

Ball Screw Specifications	
Ball size	$\phi 3.175$
Number of thread	1
Thread direction	Right
Shaft root dia.	$\phi 12.2$
Number of circuit	3.7×1
Shaft, Nut material	SCM415H
Surface hardness	HRC58~62 (Thread area)
Anti-rust treatment	Anti-rust oil

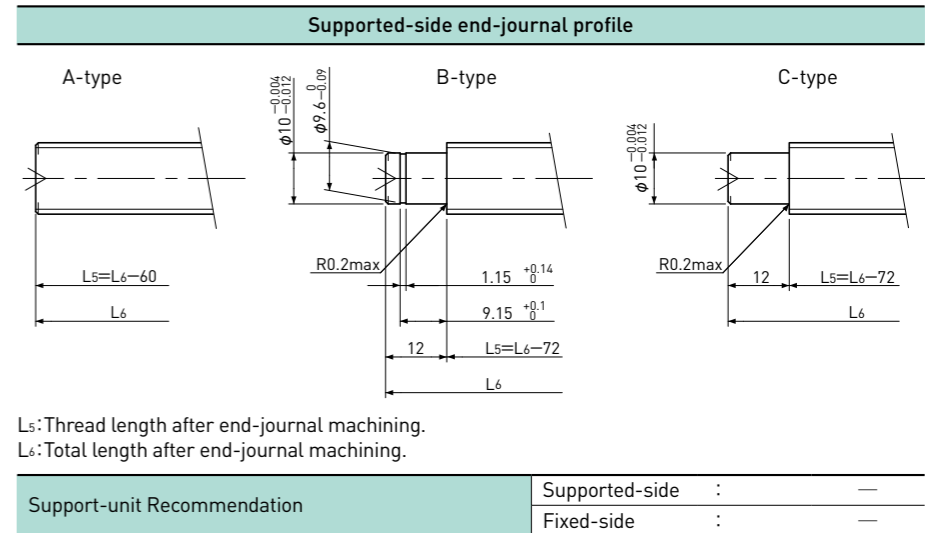

Unit:mm

Ball Screw Model	Travel	Grade	Shaft length				Lead accuracy		Total Run-out	Axial play	Preload Torque Nm	Basic Load Rating N	
			L ₁	L ₂	L ₃	L ₄	Travel deviation e _p	Variation V ₀				Dynamic Ca	Static Coa
SG1505-340R400C5	305	C5	340	345	355	400	±0.025	0.020	0.055	~0.005	—	8900	17000
SG1505-540R600C5	505	C5	540	545	555	600	±0.030	0.023	0.075				

Note) Please refer to page A206 for order code of end-journal machining.

Standard products in stock SG series

SG1510

Shaft dia. $\phi 15$ Lead 10mm

C5

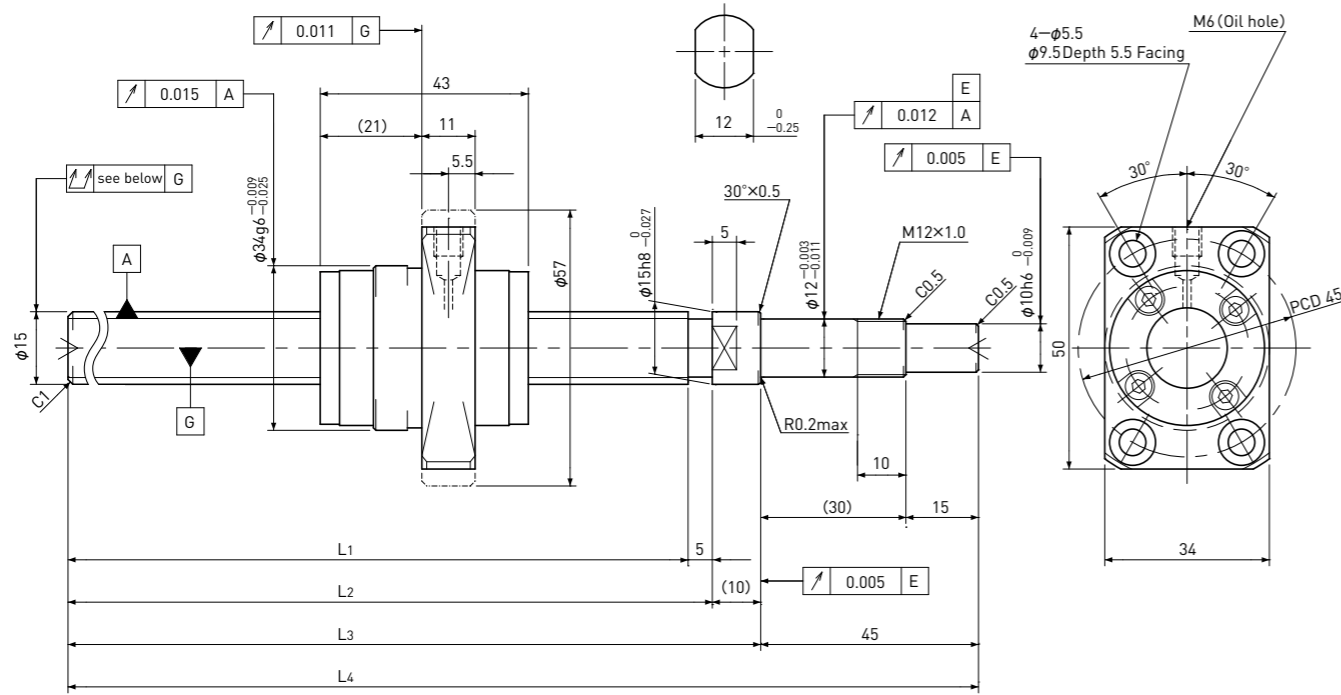

Unit:mm

Ball Screw Specifications	
Ball size	$\phi 3.175$
Number of thread	2
Thread direction	Right
Shaft root dia.	$\phi 12.2$
Number of circuit	2.7 \times 2
Shaft, Nut material	SCM415H
Surface hardness	HRC58~62 (Thread area)
Anti-rust treatment	Anti-rust oil

Supported-side end-journal profile		
A-type	B-type	C-type
L5=L6-60	L5=L6-72	L5=L6-72
Ls: Thread length after end-journal machining. L6: Total length after end-journal machining.		
Support-unit Recommendation		Supported-side : — Fixed-side : —

D-type : Other than the above.

Unit:mm

Ball Screw Model	Travel	Grade	Shaft length				Lead accuracy		Total Run-out	Axial play	Preload Torque Nm	Basic Load Rating N	
			L1	L2	L3	L4	Travel deviation e_p	Variation V_u				Dynamic C_a	Static C_oa
SG1510-340R400C5	295	C5	340	345	355	400	± 0.025	0.020	0.055	~0.005	—	12000	25000
SG1510-540R600C5	495	C5	540	545	555	600	± 0.030	0.023	0.075				

Note) Please refer to page A206 for order code of end-journal machining.

Standard products in stock SG series

SG1520

Shaft dia. $\phi 15$ Lead 20mm

C5

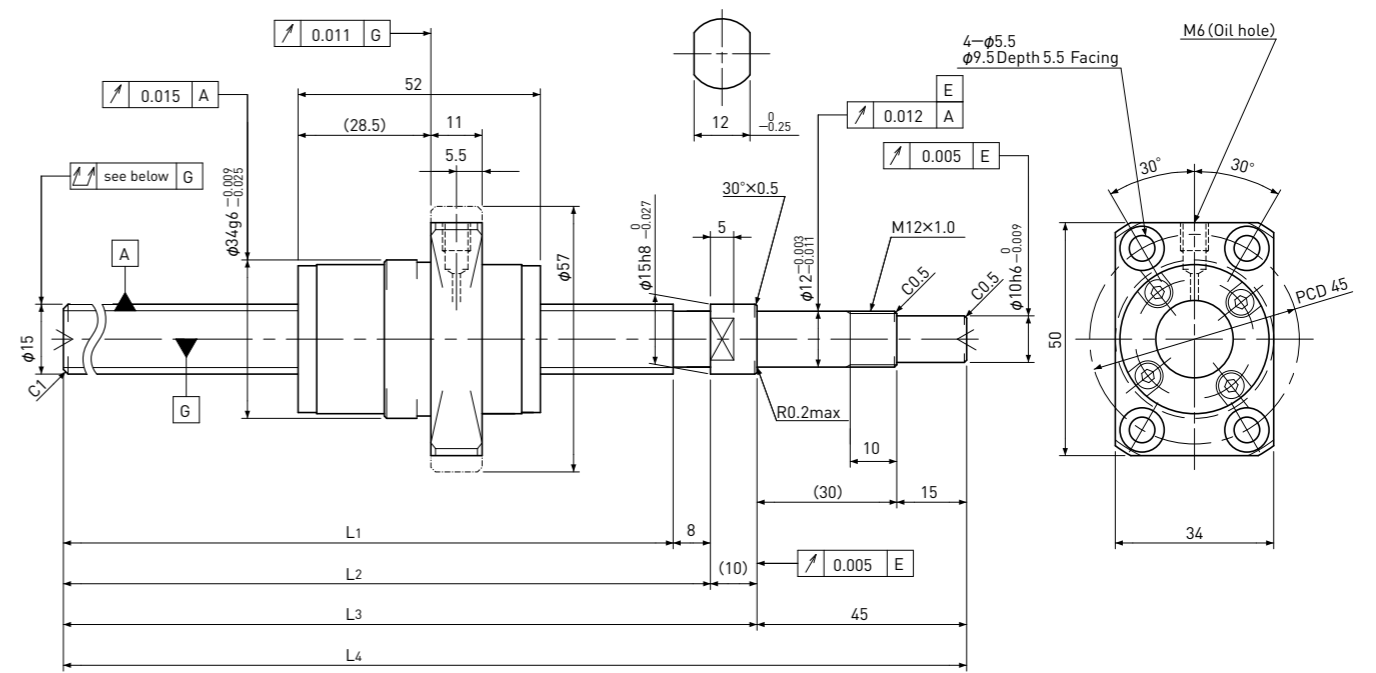

Unit:mm

Ball Screw Specifications	
Ball size	$\phi 3.175$
Number of thread	2
Thread direction	Right
Shaft root dia.	$\phi 12.4$
Number of circuit	1.7 \times 2
Shaft, Nut material	SCM415H
Surface hardness	HRC58~62 (Thread area)
Anti-rust treatment	Anti-rust oil

Supported-side end-journal profile		
A-type	B-type	C-type
L5=L6-63	L5=L6-75	L5=L6-75
Ls: Thread length after end-journal machining. L6: Total length after end-journal machining.		
Support-unit Recommendation		Supported-side : — Fixed-side : —

D-type : Other than the above.

Unit:mm

Ball Screw Model	Travel	Grade	Shaft length				Lead accuracy		Total Run-out	Axial play	Preload Torque Nm	Basic Load Rating N	
			L1	L2	L3	L4	Travel deviation e_p	Variation V_u				Dynamic C_a	Static C_oa
SG1520-337R400C5	285	C5	337	345	355	400	± 0.025	0.020	0.055	~0.005	—	8000	16000
SG1520-537R600C5	485	C5	537	545	555	600	± 0.030	0.023	0.075				

Note) Please refer to page A206 for order code of end-journal machining.